

NISSAN
FORKLIFT

Platinum II Series

Cushion Tire / Engine Powered Models / LPG, Gasoline, Dual Fuel

3,000 – 8,000 lb.
Capacities



Platinum II cushion series

Dimensions

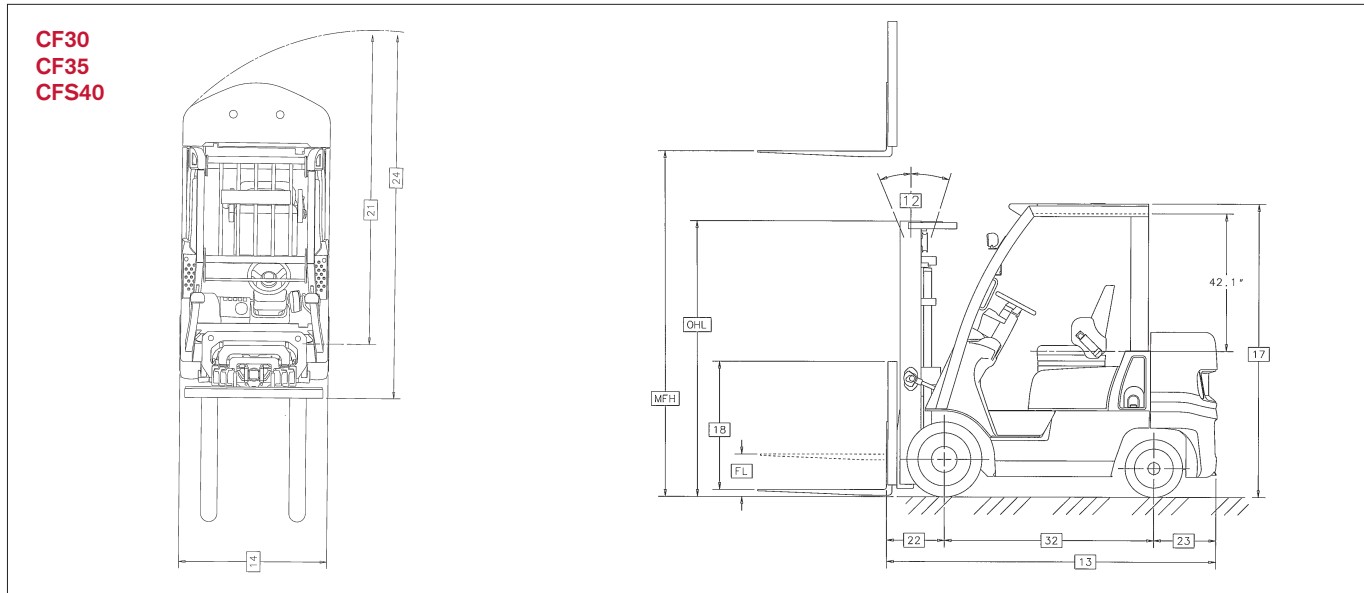

Mast Specifications & Rated Capacities

	Mast Name	Maximum Fork Height	Overall Height Lowered	Free Lift	Tilt Angle Forward/Backward	Rated Capacity at 24" Load Center		
						CF30	CF35	CFS40
TWO STAGE (Wide view 2W)	2W203T	80	62.1	4	10/5	3000	3500	4000
	2W270	106	71.1	4	5/5	3000	3500	4000
	2W300	118	77	4	5/10	3000	3500	4000
	2W330	130	82.9	4	5/10	3000	3500	4000
	2W350	138	88.2	4	5/10	3000	3500	4000
	2W370	146	93.1	4	5/10	3000	3500	4000
	2W400	157	100.6	4	5/10	3000	3500	3900
	2W450	177	110.5	4	5/5	2900	2700	2950
2W500	197	120.3	4	5/5	1600	1400	1700	
TWO STAGE (Full free 2F)	2F270	105.5	72	47.4	5/10	3000	3500	4000
	2F300	117.5	78	53.4	5/10	3000	3500	4000
	2F330	129.5	84	59.4	5/10	3000	3500	4000
	2F350	137.5	88	63.4	5/10	3000	3500	4000
	2F370	145.5	92	67.4	5/10	3000	3500	3950
	2F400	157.5	98	73.4	5/10	2950	3450	3800
THREE STAGE (Full free 3F)	3F385	152	71.1	46.9	5/5	2950	3450	3900
	3F430	169	77	52.8	5/5	2850	3350	3800
	3F475	187	82.9	58.7	5/5	2750	3200	3650
	3F515	203	88.2	64	5/5	2650	3100	3200
	3F550	217	93.1	68.9	5/5	2550	2450	2000
	3F600	236	100.6	76.4	5/5	1650	1200	900
	3F650	256	110.5	86.2	5/5	900	500	200
THREE STAGE OPTIVIEW™ (3V)	3V360	142	71.1	47.6	5/5	2900	3400	3850
	3V405	159	77	53.5	5/5	2850	3350	3750
	3V450	177	82.9	59.4	5/5	2750	3200	3650
	3V490	193	88.2	64.8	5/5	2650	3100	3300
	3V525	207	93.1	69.7	5/5	2550	2450	2400
	3V575	226	100.6	77.2	5/5	1650	1200	1100
	3V633	249	110.5	87.0	5/5	900	800	600

3,000 / 3,500 / 4,000 lb. capacities

Main Truck Specifications

				Nissan	Nissan	Nissan			
CHARACTERISTICS	1	Manufacturer's Name		Nissan	Nissan	Nissan	1		
	2	Model	Model designation	CF30	CF35	CFS40	2		
			Long model code	MCP1F1A15LV / DV	MCP1F1A18LV / DV	MCP1F1A20LV / DV			
	3	Rated Load Capacity		lb (kg)	3000 (1500)	3500 (1750)	4000 (2000)	3	
	4	Load Center	Distance		in (mm)	24 (500)	24 (500)	24 (500)	4
	5	Power Type				LP - G/LP	LP - G/LP	LP - G/LP	5
6	Operator Orientation				Sit	Sit	Sit	6	
DIMENSIONS	7	Tire Type	Front & rear		Cushion	Cushion	Cushion	7	
	8	Wheels	Number (x=driven) front/rear		2 x / 2	2 x / 2	2 x / 2	8	
	9	Mast	Maximum fork height	in (mm)	130 (3300)	130 (3300)	130 (3300)	9	
			Standard freelif	in (mm)	4 (100)	4 (100)	4 (100)	10	
	11	Forks	Thickness & width	in (mm)	1.5 x 4 (40x100)	1.5 x 4 (40x100)	1.5 x 4 (40x100)	11	
			Length (STD)	in (mm)	42 (1070)	42 (1070)	42 (1070)		
	12	Tilt Angle	Standard mast - fwd/back	degree	5 / 10	5 / 10	5 / 10	12	
	13	Overall Dimensions	Length (to face of forks)	in (mm)	81.9 (2080)	83.1 (2110)	84.4 (2145)	13	
			Width (standard tires)	in (mm)	38.2 (970)	38.2 (970)	38.2 (970)	14	
			Mast lowered (OHL)	in (mm)	82.9 (2105)	82.9 (2105)	82.9 (2105)	15	
			Mast extended with LBR	in (mm)	179.3 (4555)	179.3 (4555)	179.3 (4555)	16	
			Height - top of OHG	in (mm)	81.1 (2060)	81.1 (2060)	81.1 (2060)	17	
			Height - top of standard LBR	in (mm)	48 (1220)	48 (1220)	48 (1220)	18	
			Width - standard carriage	in (mm)	32.4 (823)	32.4 (823)	32.4 (823)	19	
	20	Grade Clearance	Ramp breakover angle	tan (%)	43	43	43	20	
			Departure angle	tan (%)	35	30	28		
			Approach angle	tan (%)	26	26	26		
	21	Turning Radius	Minimum outside	in (mm)	68.3 (1735)	69.5 (1765)	70.9 (1800)	21	
	22	Overhang	Front	in (mm)	15.4 (390)	15.4 (390)	15.4 (390)	22	
Rear			in (mm)	19.7 (500)	20.9 (530)	22.2 (565)	23		
24	Min Right Angle Stack	Add load length & clearance	in (mm)	83.7 (2125)	84.9 (2155)	86.3 (2190)	24		
25	Speeds Maximum	Travel - forward or reverse	mph (kmh)	10.9 (17.5)	10.9 (17.5)	10.9 (17.5)	25		
		Lift - full/empty	fpm (mm/sec)	122/127.9 (620/650)	122/127.9 (620/650)	122/127.9 (620/650)	26		
		Lowering - full/empty	fpm (mm/sec)	98.4 (500)	98.4 (500)	98.4 (500)			
27	Drawbar Pull Maximum	LP - full	lb (kg)	3417 (1550)	3417 (1550)	3417 (1550)	27		
		LP - empty	lb (kg)	1543 (700)	1543 (700)	1543 (700)			
28	Gradeability Max (1.2 mph)	LP - full/empty	tan (%)	38 / 20	38 / 18	38 / 16	28		
29	Truck Weight	Standard truck - no load	lb (kg)	5980 (2710)	6420 (2910)	6830 (3100)	29		
30	Weight Distribution	Front axle - empty	lb (kg)	2200 (995)	2045 (925)	1880 (855)	30		
		Rear axle - empty	lb (kg)	3780 (1715)	4375 (1985)	4950 (2245)			
		Front axle - with rated load	lb (kg)	7720 (3620)	8485 (3985)	9240 (4350)			
		Rear axle - with rated load	lb (kg)	1260 (590)	1435 (675)	1590 (750)			
CHASSIS & WHEELS	31	Tire Size	Front	in	18 x 6 x 12.13	18 x 6 x 12.13	18 x 6 x 12.13	31	
			Rear	in	14 x 5 x 10	14 x 5 x 10	14 x 5 x 10		
	32	Wheelbase		in (mm)	46.9 (1190)	46.9 (1190)	46.9 (1190)	32	
	33	Tread - Center of Tire	Front / rear	in (mm)	32.3 (820)	32.3 (820)	32.3 (820)	33	
			Headroom	SIP to bottom of OHG	in (mm)	42.1 (1070)	42.1 (1070)	42.1 (1070)	
		Counterweight Height		in (mm)	45.3 (1150)	45.1 (1145)	45.1 (1145)		
		Step Height		in (mm)	17.1 (435)	17.1 (435)	17.1 (435)		
	34	Ground Clearance	Under mast	in (mm)	3.0 (75)	3.0 (75)	3.0 (75)	34	
			Under power unit	in (mm)	2.6 (65)	2.6 (65)	2.6 (65)		
			Under frame (WB center)	in (mm)	4.3 (110)	4.3 (110)	4.3 (110)		
35	Service Brake	Type		Drum and Shoe	Drum and Shoe	Drum and Shoe	35		
36	Parking Brake	Type		Hand	Hand	Hand	36		
37	Steering	Type		Full Hydraulic	Full Hydraulic	Full Hydraulic	37		
DRIVE LINE	38	Engine	Manufacturer/Model		Nissan K21	Nissan K21	Nissan K21	38	
			Rated Output	SAE gross - LP	hp (kW) @ rpm	55 (41) @ 2700	55 (41) @ 2700	55 (41) @ 2700	
		Rated Torque	SAE gross - LP	ft-lb (Nm) @ rpm	111.4 (151) @ 2000	111.4 (151) @ 2000	111.4 (151) @ 2000		
		Displacement		cu in (cm ³)	126 (2065)	126 (2065)	126 (2065)		
	39	Transmission	Type		Automatic	Automatic	Automatic	39	
		Number speeds - fwd/rev		1/1	1/1	1/1			

4,000 lb. capacity

Main Truck Specifications

				Nissan	Nissan		
CHARACTERISTICS	1	Manufacturer's Name		Nissan	Nissan	1	
	2	Model	Model designation	CF40	CFU40	2	
			Long model code	MCP1F2A20JV / LV / DV	MCU1F2A20LV / DV		
	3	Rated Load Capacity		4000 (2000)	4000 (2000)	3	
	4	Load Center	Distance	24 (500)	24 (500)	4	
	5	Power Type		G - LP - G/LP	LP - G/LP	5	
6	Operator Orientation		Sit	Sit	6		
DIMENSIONS	7	Tire Type	Front & rear	Cushion	Cushion	7	
	8	Wheels	Number (x=driven) front/rear	2 x / 2	2 x / 2	8	
	9	Mast	Maximum fork height	in (mm)	130 (3300)	130 (3300)	9
			Standard freelif	in (mm)	4.2 (105)	4.2 (105)	10
	11	Forks	Thickness & width	in (mm)	1.5 x 4 (40x100)	1.5 x 4 (40x100)	11
			Length (STD)	in (mm)	42 (1070)	42 (1070)	
	12	Tilt Angle	Standard mast - fwd/back	degree	5/10	5/10	12
	13	Overall Dimensions	Length (to face of forks)	in (mm)	89 (2260)	89 (2260)	13
			Width (standard tires)	in (mm)	42.1 (1070)	42.1 (1070)	14
			Mast lowered (OHL)	in (mm)	83.1 (2110)	83.1 (2110)	15
			Mast extended with LBR	in (mm)	179.3 (4555)	179.3 (4555)	16
			Height - top of OHG	in (mm)	82.1 (2085)	82.1 (2085)	17
			Height - top of standard LBR	in (mm)	48 (1220)	48 (1220)	18
			Width - standard carriage	in (mm)	36.2 (920)	36.2 (920)	19
	20	Grade Clearance	Ramp breakover angle	tan (%)	42	42	20
			Departure angle	tan (%)	34	34	
			Approach angle	tan (%)	29	29	
	21	Turning Radius	Minimum outside	in (mm)	76 (1930)	76 (1930)	21
	22	Overhang	Front	in (mm)	16.1 (410)	16.1 (410)	22
Rear			in (mm)	17.7 (450)	17.7 (450)	23	
24	Min Right Angle Stack	Add load length & clearance	in (mm)	92.1 (2340)	92.1 (2340)	24	
PERFORMANCE	25	Speeds Maximum	Travel - forward or reverse	mph (kmh)	10.6 (17)	10.6 (17)	25
			Lift - full/empty	fpm (mm/sec)	122/127.9 (620/650)	129.9/137.8 (660/700)	26
			Lowering - full/empty	fpm (mm/sec)	98.4 (500)	98.4 (500)	
	27	Drawbar Pull Maximum	LPG - full	lb (kg)	3638 (1650)	4189 (1900)	27
LPG - empty			lb (kg)	1870 (850)	1870 (850)		
28	Gradeability Max (1.2 mph)	LPG - full/empty	tan (%)	33 / 21	39 / 21	28	
WEIGHT	29	Truck Weight	Standard truck - no load	lb (kg)	7130 (3235)	7130 (3235)	29
	30	Weight Distribution	Front axle - empty	lb (kg)	2815 (1275)	2815 (1275)	30
			Rear axle - empty	lb (kg)	4315 (1960)	4315 (1960)	
			Front axle - with rated load	lb (kg)	9730 (4575)	9730 (4575)	
			Rear axle - with rated load	lb (kg)	1400 (660)	1400 (660)	
CHASSIS & WHEELS	31	Tire Size	Front	in	21 x 7 x 15	21 x 7 x 15	31
			Rear	in	16.25 x 6 x 11.25	16.25 x 6 x 11.25	
	32	Wheelbase		in (mm)	55.1 (1400)	55.1 (1400)	32
	33	Tread - Center of Tire	Front / rear	in (mm)	35 (890)	35 (890)	33
		Headroom	SIP to bottom of OHG	in (mm)	42.1 (1070)	42.1 (1070)	
		Counterweight Height		in (mm)	45.9 (1165)	45.9 (1165)	
		Step Height		in (mm)	16.5 (420)	16.5 (420)	
	34	Ground Clearance	Under mast	in (mm)	3.1 (80)	3.1 (80)	34
			Under power unit	in (mm)	4.1 (105)	4.1 (105)	
			Under frame (WB center)	in (mm)	5.5 (140)	5.5 (140)	
	35	Service Brake	Type		Drum and Shoe	Drum and Shoe	35
	36	Parking Brake	Type		Hand	Hand	36
37	Steering	Type		Full Hydraulic	Full Hydraulic	37	
DRIVE LINE	38	Engine	Manufacturer / Model		Nissan K21	Nissan K25	38
		Rated Output	SAE gross - LP	hp (kW) @ rpm	55 (41) @ 2700	62.9 (46.9) @ 2700	
		Rated Torque	SAE gross - LP	ft-lb (Nm) @ rpm	111.4 (151) @ 2000	138.7 (188) @ 1600	
		Displacement		cu in (cm ³)	126 (2065)	151.8 (2488)	
	39	Transmission	Type		Automatic	Automatic	39
		Number speeds - fwd/rev		1/1	1/1		

Platinum II cushion series

Dimensions

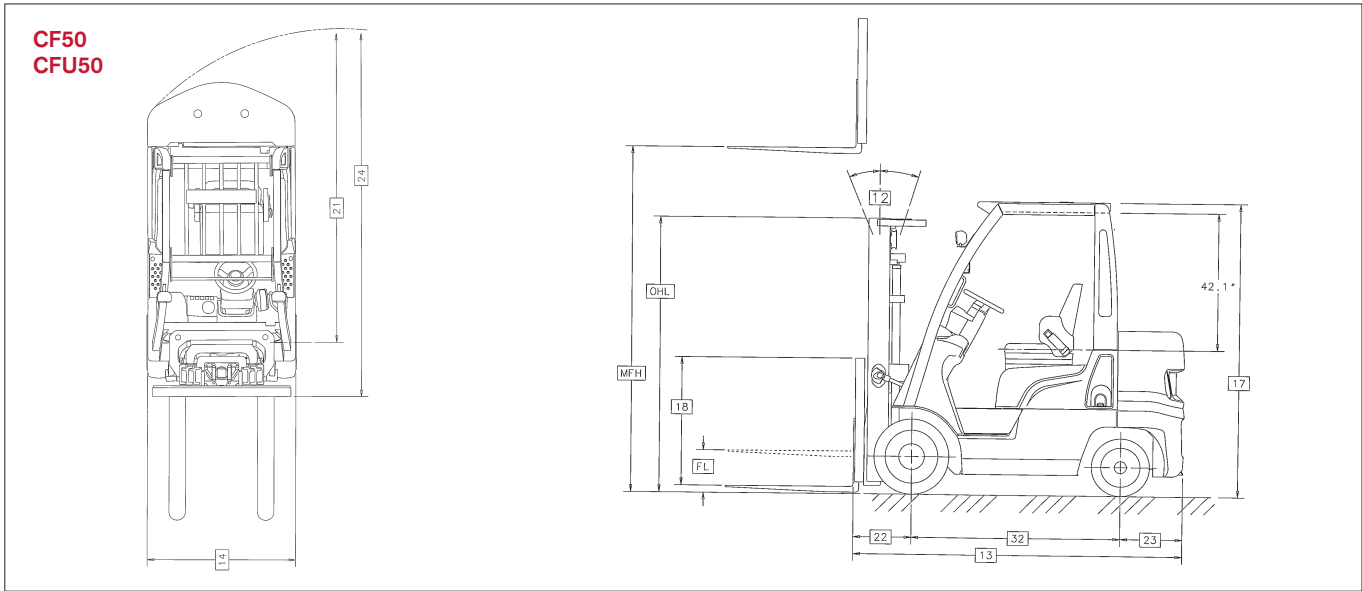

Mast Specifications & Rated Capacities

	Mast Name	Maximum Fork Height	Overall Height Lowered	Free Lift	Tilt Angle Forward/Backward	Rated Capacity at 24" Load Center
TWO STAGE (Wide view 2W)	2W203T	80	62.1	4	10/5	5000
	2W270	106	71.3	4.2	5/5	5000
	2W300	118	77.2	4.2	5/5	5000
	2W330	130	83.1	4.2	5/10	5000
	2W350	138	88.4	4.2	5/10	5000
	2W370	146	93.3	4.2	5/5	5000
	2W400	157	100.8	4.2	5/10	5000
	2W450	177	110.6	4.2	5/5	4850
2W500	197	120.5	4.2	5/5	4650	
TWO STAGE (Full free 2F)	2F270	105.5	72	47.4	5/10	5000
	2F300	117.5	78	53.4	5/10	5000
	2F330	129.5	84	59.4	5/10	5000
	2F350	137.5	88	63.4	5/10	5000
	2F370	145.5	92	67.4	5/10	5000
	2F400	157.5	98	73.4	5/10	4950
THREE STAGE (Full free 3F)	3F385	152	71.3	46.9	5/5	5000
	3F430	169	77.2	52.8	5/5	4850
	3F475	187	83.1	58.7	5/5	4700
	3F515	203	88.4	64.0	5/5	4550
	3F550	217	93.3	68.9	5/5	4000
	3F600	236	100.8	76.4	5/5	3000
	3F650	256	110.6	86.2	5/5	2300
3F700	276	120.5	96.1	5/5	1200	
THREE STAGE OPTIVIEW™ (3V)	3V360	142	71.3	47.8	5/5	4800
	3V405	159	77.2	53.7	5/5	4750
	3V450	177	83.1	59.6	5/5	4700
	3V490	193	88.4	64.9	5/5	4550
	3V525	207	93.3	69.8	5/5	4000
	3V575	226	100.8	77.3	5/5	3000
	3V633	249	110.6	87.2	5/5	2300
	3V688	271	120.5	97.0	5/5	1300

5,000 lb. capacity

Main Truck Specifications

CHARACTERISTICS				Nissan	Nissan	
1	Manufacturer's Name			Nissan	Nissan	1
2	Model	Model designation		CF50	CFU50	2
		Long model code		MCP1F2A25JV / LV / DV	MCU1F2A25LV / DV	
3	Rated Load Capacity		lb (kg)	5000 (2500)	5000 (2500)	3
4	Load Center	Distance	in (mm)	24 (500)	24 (500)	4
5	Power Type			G - LP - G/LP	LP - G/LP	5
6	Operator Orientation			Sit	Sit	6
7	Tire Type	Front & rear		Cushion	Cushion	7
8	Wheels	Number (x=driven) front/rear		2 x / 2	2 x / 2	8
9	Mast	Maximum fork height	in (mm)	130 (3300)	130 (3300)	9
		Standard freelif	in (mm)	4.2 (105)	4.2 (105)	10
11	Forks	Thickness & width	in (mm)	1.5 x 4 (40x100)	1.5 x 4 (40x100)	11
		Length (STD)	in (mm)	42 (1070)	42 (1070)	
12	Tilt Angle	Standard mast - fwd/back	degree	5/10	5/10	12
13	Overall Dimensions	Length (to face of forks)	in (mm)	91.3 (2320)	91.3 (2320)	13
		Width (standard tires)	in (mm)	42.1 (1070)	42.1 (1070)	14
		Mast lowered (OHL)	in (mm)	83.1 (2110)	83.1 (2110)	15
		Mast extended with LBR	in (mm)	179.3 (4555)	179.3 (4555)	16
		Height - top of OHG	in (mm)	82.1 (2085)	82.1 (2085)	17
		Height - top of standard LBR	in (mm)	48 (1220)	48 (1220)	18
		Width - standard carriage	in (mm)	36.2 (920)	36.2 (920)	19
20	Grade Clearance	Ramp breakover angle	tan (%)	42	42	20
		Departure angle	tan (%)	30	30	
		Approach angle	tan (%)	26	26	
21	Turning Radius	Minimum outside	in (mm)	78.3 (1990)	78.3 (1990)	21
22	Overhang	Front	in (mm)	16.1 (410)	16.1 (410)	22
		Rear	in (mm)	20.1 (510)	20.1 (510)	23
24	Min Right Angle Stack	Add load length & clearance	in (mm)	94.4 (2400)	94.4 (2400)	24
25	Speeds Maximum	Travel - forward or reverse	mph (kmh)	10.6 (17)	10.6 (17)	25
		Lift - full/empty	fpm (mm/sec)	118.1/127.9 (600/650)	129.9/137.8 (660/700)	26
		Lowering - full/empty	fpm (mm/sec)	98.4 (500)	98.4 (500)	
27	Drawbar Pull Maximum	LP - full	lb (kg)	3638 (1650)	4189 (1900)	27
		LP - empty	lb (kg)	1764 (800)	1764 (800)	
28	Gradeability Max (1.2 mph)	LP - full/empty	tan (%)	28 / 16	33 / 16	28
29	Truck Weight	Standard truck - no load	lb (kg)	7940 (3600)	7940 (3600)	29
30	Weight Distribution	Front axle - empty	lb (kg)	2590 (1175)	2590 (1175)	30
		Rear axle - empty	lb (kg)	5350 (2425)	5350 (2425)	
		Front axle - with rated load	lb (kg)	11375 (5360)	11375 (5360)	
		Rear axle - with rated load	lb (kg)	1565 (740)	1565 (740)	
31	Tire Size	Front	in	21 x 7 x 15	21 x 7 x 15	31
		Rear	in	16.25 x 6 x 11.25	16.25 x 6 x 11.25	
32	Wheelbase		in (mm)	55.1 (1400)	55.1 (1400)	32
33	Tread - Center of Tire	Front / rear	in (mm)	35 (890)	35 (890)	33
	Headroom	SIP to bottom of OHG	in (mm)	42.1 (1070)	42.1 (1070)	
	Counterweight Height		in (mm)	45.9 (1165)	45.9 (1165)	
	Step Height		in (mm)	16.5 (420)	16.5 (420)	
34	Ground Clearance	Under mast	in (mm)	3.1 (80)	3.1 (80)	34
		Under power unit	in (mm)	4.1 (105)	4.1 (105)	
		Under frame (WB center)	in (mm)	5.5 (140)	5.5 (140)	
35	Service Brake	Type		Drum and Shoe	Drum and Shoe	35
36	Parking Brake	Type		Hand	Hand	36
37	Steering	Type		Full Hydraulic	Full Hydraulic	37
38	Engine	Manufacturer / Model		Nissan K21	Nissan K25	38
	Rated Output	SAE gross - LP	hp (kW) @ rpm	55 (41) @ 2700	62.9 (46.9) @ 2700	
	Rated Torque	SAE gross - LP	ft-lb (Nm) @ rpm	111.4 (151) @ 2000	138.7 (188) @ 1600	
	Displacement		cu in (cm ³)	126 (2065)	151.8 (2488)	
39	Transmission	Type		Automatic	Automatic	39
		Number speeds - fwd/rev		1/1	1/1	

Platinum II cushion series

Dimensions

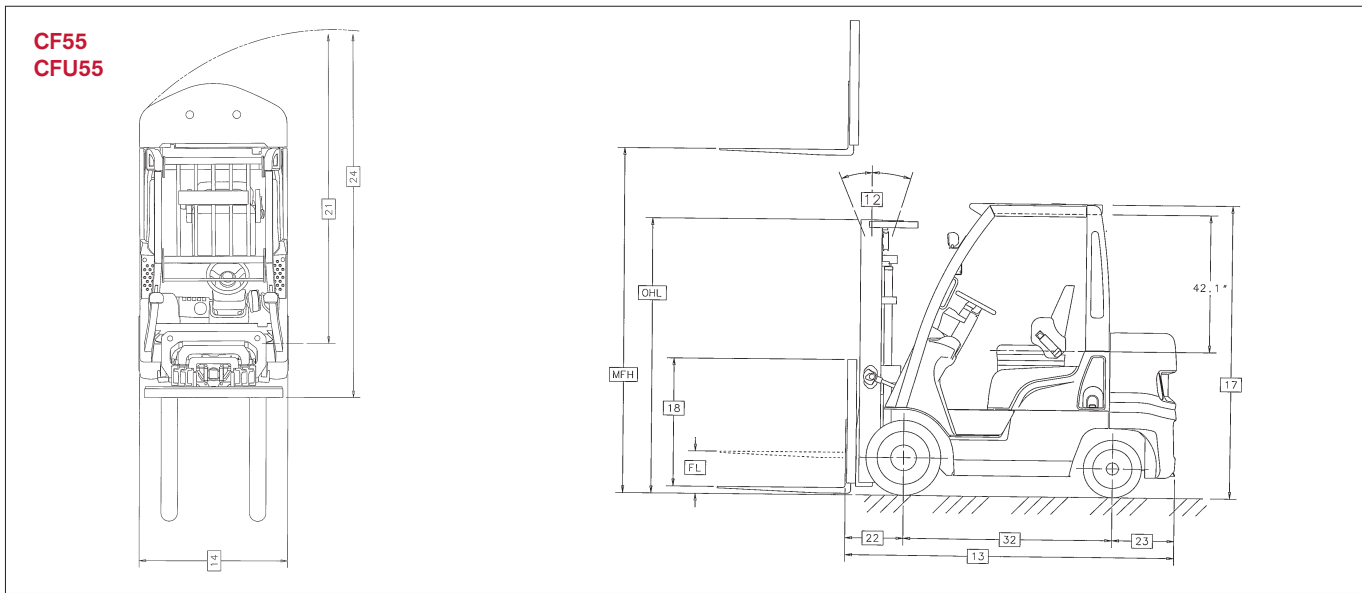

Mast Specifications & Rated Capacities

	Mast Name	Maximum Fork Height	Overall Height Lowered	Free Lift	Tilt Angle Forward/Backward	Rated Capacity at 24" Load Center
TWO STAGE (Wide view 2H)	2H270	106	70.9	6.7	5/10	5500
	2H300	118	76.8	6.7	5/10	5500
	2H330	130	82.7	6.7	5/10	5500
	2H350	138	88	6.7	5/10	5500
	2H370	146	92.9	10.2	5/10	5500
	2H400	157	100.4	10.2	5/10	5500
	2H450	177	110.2	10.2	5/5	5300
	2H500	197	120.1	10.2	5/5	5100
TWO STAGE (Full free 2F)	2F270	105.5	71.7	45.3	5/10	5500
	2F300	117.5	77.7	51.3	5/10	5500
	2F330	129.5	83.7	57.3	5/10	5500
	2F350	137.5	87.7	61.3	5/10	5500
	2F370	145.5	91.7	65.3	5/10	5500
	2F400	157.5	97.7	71.3	5/10	5400
THREE STAGE (Full free 3F)	3F385	152	76.7	56.1	5/5	5500
	3F430	169	82.6	62	5/5	5300
	3F475	187	87.9	67.3	5/5	5150
	3F515	203	92.8	72.2	5/5	5000
	3F550	217	100.3	79.7	5/5	4400
	3F600	236	110.1	89.6	5/5	3200
	3F650	256	120	99.4	5/5	2300
	3F700	276	129.8	109.3	5/5	1100
THREE STAGE OPTIVIEW™ (3V)	3V385	152	76.9	49.4	5/5	5250
	3V430	169	82.8	55.3	5/5	5200
	3V470	185	88.1	61.2	5/5	5150
	3V505	199	93.0	66.5	5/5	5000
	3V555	219	100.5	71.5	5/5	4400
	3V600	236	110.3	78.9	5/5	3000
	3V650	256	120.2	88.8	5/5	2200
	3V700	276	130.0	98.6	5/5	1150

5,500 lb. capacity

Main Truck Specifications

CHARACTERISTICS				Nissan	Nissan	
1	Manufacturer's Name			Nissan	Nissan	1
2	Model	Model designation		CF55	CFU55	2
		Long model code		MCP1F2A28JV / LV / DV	MCU1F2A28LV / DV	
3	Rated Load Capacity		lb (kg)	5500 (2750)	5500 (2750)	3
4	Load Center	Distance	in (mm)	24 (500)	24 (500)	4
5	Power Type			G - LP - G/LP	LP - G/LP	5
6	Operator Orientation			Sit	Sit	6
7	Tire Type	Front & rear		Cushion	Cushion	7
8	Wheels	Number (x=driven) front/rear		2 x / 2	2 x / 2	8
9	Mast	Maximum fork height	in (mm)	130 (3300)	130 (3300)	9
		Standard freelif	in (mm)	6.7 (170)	6.7 (170)	10
11	Forks	Thickness & width	in (mm)	1.5 x 4 (40x100)	1.5 x 4 (40x100)	11
		Length (STD)	in (mm)	42 (1070)	42 (1070)	
12	Tilt Angle	Standard mast - fwd/back	degree	5/10	5/10	12
13	Overall Dimensions	Length (to face of forks)	in (mm)	93.9 (2385)	93.9 (2385)	13
		Width (standard tires)	in (mm)	43.1(1095)	43.1(1095)	14
		Mast lowered (OHL)	in (mm)	82.7 (2100)	82.7 (2100)	15
		Mast extended with LBR	in (mm)	179.3 (4555)	179.3 (4555)	16
		Height - top of OHG	in (mm)	82.1 (2085)	82.1 (2085)	17
		Height - top of standard LBR	in (mm)	48 (1220)	48 (1220)	18
		Width - standard carriage	in (mm)	40.2 (1020)	40.2 (1020)	19
20	Grade Clearance	Ramp breakover angle	tan (%)	42	42	20
		Departure angle	tan (%)	28	28	
		Approach angle	tan (%)	26	26	
21	Turning Radius	Minimum outside	in (mm)	79.5 (2020)	79.5 (2020)	21
22	Overhang	Front	in (mm)	17.3 (440)	17.3 (440)	22
		Rear	in (mm)	21.5 (545)	21.5 (545)	23
24	Min Right Angle Stack	Add load length & clearance	in (mm)	96.8 (2460)	96.8 (2460)	24
25	Speeds Maximum	Travel - forward or reverse	mph (kmh)	10.6 (17)	10.6 (17)	25
		Lift - full/empty	fpm (mm/sec)	94.5/102.4 (480/520)	104.3/110.2 (530/560)	26
		Lowering - full/empty	fpm (mm/sec)	98.4 (500)	98.4 (500)	
27	Drawbar Pull Maximum	LP - full	lb (kg)	3638 (1650)	4189 (1900)	27
		LP - empty	lb (kg)	1653 (750)	1653 (750)	
28	Gradeability Max (1.2 mph)	LP - full/empty	tan (%)	27 / 16	32 / 16	28
29	Truck Weight	Standard truck - no load	lb (kg)	8860 (4015)	8860 (4015)	29
30	Weight Distribution	Front axle - empty	lb (kg)	2705 (1225)	2705 (1225)	30
		Rear axle - empty	lb (kg)	6155 (2790)	6155 (2790)	
		Front axle - with rated load	lb (kg)	12355 (5820)	12355 (5820)	
		Rear axle - with rated load	lb (kg)	2005 (945)	2005 (945)	
31	Tire Size	Front	in	21 x 8 x 15	21 x 8 x 15	31
		Rear	in	16.25 x 6 x 11.25	16.25 x 6 x 11.25	
32	Wheelbase		in (mm)	55.1 (1400)	55.1 (1400)	32
33	Tread - Center of Tire	Front / rear	in (mm)	35.8/35 (910/890)	35.8/35 (910/890)	33
	Headroom	SIP to bottom of OHG	in (mm)	42.1 (1070)	42.1 (1070)	
	Counterweight Height		in (mm)	45.7 (1160)	45.7 (1160)	
	Step Height		in (mm)	16.5 (420)	16.5 (420)	
34	Ground Clearance	Under mast	in (mm)	2.8 (70)	2.8 (70)	34
		Under power unit	in (mm)	3.5 (90)	3.5 (90)	
		Under frame (WB center)	in (mm)	5.5 (140)	5.5 (140)	
35	Service Brake	Type		Drum and Shoe	Drum and Shoe	35
36	Parking Brake	Type		Hand	Hand	36
37	Steering	Type		Full Hydraulic	Full Hydraulic	37
38	Engine	Manufacturer / Model		Nissan K21	Nissan K25	38
	Rated Output	SAE gross - LP	hp (kW) @ rpm	55 (41) @ 2700	62.9 (46.9) @ 2700	
	Rated Torque	SAE gross - LP	ft-lb (Nm) @ rpm	111.4 (151) @ 2000	138.7 (188) @ 1600	
	Displacement		cu in (cm ³)	126 (2065)	151.8 (2488)	
39	Transmission	Type		Automatic	Automatic	39
		Number speeds - fwd/rev		1/1	1/1	

Platinum II cushion

Dimensions

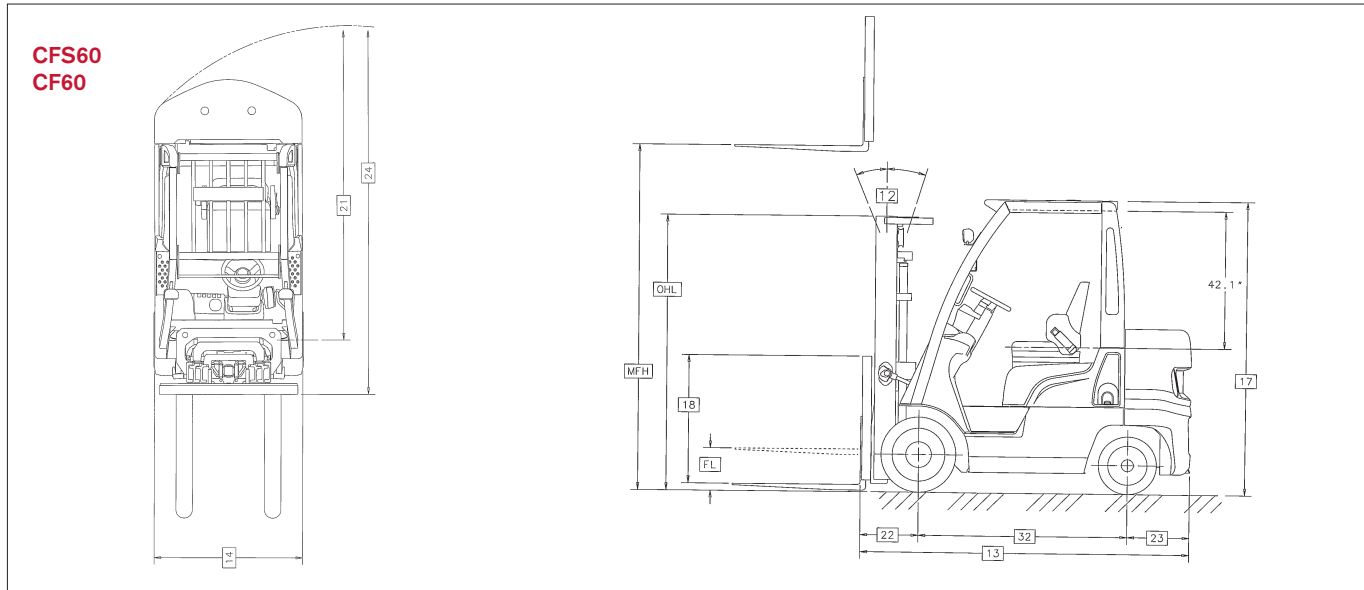

Mast Specifications & Rated Capacities

	Mast Name	Maximum Fork Height	Overall Height Lowered		Free Lift	Tilt Angle Forward/Backward	Rated Capacity at 24" Load Center	
			CFS60	CF60			CFS60	CF60
TWO STAGE (Wide view 2H)	2H270	106	70.9	71.3	7.1	5/10	6000	6000
	2H300	118	76.8	77.2	7.1	5/10	6000	6000
	2H330	130	82.7	83.1	7.1	5/10	6000	6000
	2H350	138	88	88.4	7.1	5/10	6000	6000
	2H370	146	92.9	93.3	10.6	5/10	6000	6000
	2H400	157	100.4	100.8	10.6	5/10	6000	6000
	2H450	177	110.2	110.6	10.6	5/5	5800	5850
	2H500	197	120.1	120.5	10.6	5/5	5550	5650
TWO STAGE (Full free 2F)	2F270	105.5	71.7	72	45.7	5/10	6000	6000
	2F300	117.5	77.7	78	51.7	5/10	6000	6000
	2F330	129.5	83.7	84	57.7	5/10	6000	6000
	2F350	137.5	87.7	88	61.7	5/10	6000	6000
	2F370	145.5	91.7	92	65.7	5/10	6000	6000
	2F400	157.5	97.7	98	71.7	5/10	5950	6000
THREE STAGE (Full free 3F)	3F385	152	76.7	77.2	56.1	5/5	6000	6000
	3F430	169	82.6	83.1	62	5/5	5800	5800
	3F475	187	87.9	88.4	67.3	5/5	5650	5650
	3F515	203	92.8	93.3	72.2	5/5	5450	5500
	3F550	217	100.3	100.8	79.7	5/5	4650	4750
	3F600	236	110.1	110.6	89.6	5/5	3400	3500
	3F650	256	120	120.5	99.4	5/5	2300	2600
	3F700	276	129.8	130.3	109.3	5/5	600	1000
THREE STAGE OPTVIEW™ (3V)	3V385	152	76.9	77.2	49.4	5/5	5600	5600
	3V430	169	82.8	83.1	55.3	5/5	5550	5550
	3V470	185	88.1	88.4	61.2	5/5	5450	5450
	3V505	199	93	93.3	66.5	5/5	5300	5300
	3V555	219	100.5	100.8	71.5	5/5	4500	4500
	3V600	236	110.3	110.6	78.9	5/5	3200	3300
	3V650	256	120.2	120.5	88.8	5/5	1600	1800
	3V700	276	130	130.3	98.6	5/5	700	1000

6,000 lb. capacity

Main Truck Specifications

				Nissan	Nissan			
CHARACTERISTICS	1	Manufacturer's Name		Nissan	Nissan	1		
	2	Model	Model designation	CFS60	CF60	2		
			Long model code	MCU1F2A30LV / DV	MCUG1F2F30LV / DV			
	3	Rated Load Capacity		lb (kg)	6000 (3000)	6000 (3000)	3	
	4	Load Center	Distance		in (mm)	24 (500)	24 (500)	4
	5	Power Type			LP - G/LP	LP - G/LP	5	
6	Operator Orientation			Sit	Sit	6		
DIMENSIONS	7	Tire Type	Front & rear		Cushion	Cushion	7	
	8	Wheels	Number (x=driven) front/rear		2 x / 2	2 x /2	8	
	9	Mast	Maximum fork height		in (mm)	130 (3300)	130 (3300)	9
			Standard freelif		in (mm)	7.1 (180)	7.1 (180)	10
	11	Forks	Thickness & width		in (mm)	2 x 5 (50x125)	2 x 5 (50x125)	11
			Length (STD)		in (mm)	42 (1070)	42 (1070)	
	12	Tilt Angle	Standard mast - fwd/back		degree	5/10	5/10	12
	13	Overall Dimensions	Length (to face of forks)		in (mm)	95.3 (2420)	96.5 (2450)	13
			Width (standard tires)		in (mm)	43.1 (1095)	43.9 (1115)	14
			Mast lowered (OHL)		in (mm)	82.7 (2100)	83.1 (2110)	15
			Mast extended with LBR		in (mm)	179.3 (4555)	175 (4445)	16
			Height - top of OHG		in (mm)	82.1 (2085)	82.3 (2090)	17
			Height - top of standard LBR		in (mm)	48 (1220)	48 (1220)	18
			Width - standard carriage		in (mm)	40.2 (1020)	40.2 (1020)	19
	20	Grade Clearance	Ramp breakover angle		tan (%)	42	44	20
			Departure angle		tan (%)	27	35	
			Approach angle		tan (%)	26	24	
	21	Turning Radius	Minimum outside		in (mm)	80.7 (2050)	80.9 (2055)	21
	22	Overhang	Front		in (mm)	17.7 (450)	17.1 (435)	22
Rear				in (mm)	22.4 (570)	20.1 (510)	23	
24	Min Right Angle Stack	Add load length & clearance		in (mm)	98.4 (2500)	98.0 (2490)	24	
PERFORMANCE	25	Speeds Maximum	Travel - forward or reverse		mph (kmh)	10.6 (17)	11.5 (18.5) fwd / 9.9 (16) rev	25
			Lift - full/empty		fpm (mm/sec)	104.3/110.2 (530/560)	104.3/110.2 (530/560)	26
			Lowering - full/empty		fpm (mm/sec)	98.4 (500)	98.4 (500)	
	27	Drawbar Pull Maximum	LP - full load		lb (kg)	4189 (1900)	3009 (1365)	27
LP - empty				lb (kg)	1764 (800)	2535 (1150)		
28	Gradeability Max (1.2 mph)	LP - full/empty		tan (%)	28 / 16	44 / 18	28	
WEIGHT	29	Truck Weight	Standard truck - no load		lb (kg)	9350 (4240)	9610 (4360)	29
	30	Weight Distribution	Front axle - empty		lb (kg)	2790 (1265)	3450 (1565)	30
			Rear axle - empty		lb (kg)	6560 (2975)	6160 (2795)	
			Front axle - with rated load		lb (kg)	13360 (6300)	13715 (6465)	
			Rear axle - with rated load		lb (kg)	1990 (940)	1895 (895)	
CHASSIS & WHEELS	31	Tire Size	Front		in	21 x 8 x 15	22 x 8 x 16	31
			Rear		in	16.25 x 6 x 11.25	18 x 6 x 12.12	
	32	Wheelbase		in (mm)	55.1 (1400)	59.1 (1500)	32	
	33	Tread - Center of Tire	Front		in (mm)	35.8 (910)	35.8 (910)	33
			Rear		in (mm)	35 (890)	36.6 (930)	
		Headroom	SIP to bottom of OHG		in (mm)	42.1 (1070)	42.1 (1070)	
		Counterweight Height			in (mm)	45.7 (1160)	46.5 (1180)	
		Step Height			in (mm)	16.5 (420)	17.1 (435)	
	34	Ground Clearance	Under mast		in (mm)	2.8 (70)	3.1 (80)	34
			Under power unit		in (mm)	3.5 (90)	3.7 (95)	
			Under frame (WB center)		in (mm)	5.5 (140)	5.7 (145)	
35	Service Brake	Type			Drum and Shoe	Drum and Shoe	35	
36	Parking Brake	Type			Hand	Hand	36	
37	Steering	Type			Full Hydraulic	Full Hydraulic	37	
38	Engine	Model			Nissan K25	Nissan K25	38	
DRIVE LINE		Rated Output	SAE gross - LP		hp (kW) @ rpm	62.9 (46.9) @ 2700	62.9 (46.9) @ 2700	
		Rated Torque	SAE gross - LP		ft-lb (Nm) @ rpm	138.7 (188) @ 1600	138.7 (188) @ 1600	
		Displacement			cu in (cm³)	151.8 (2488)	151.8 (2488)	
	39	Transmission	Type			Automatic	Automatic	39
Number speeds - fwd/rev					1/1	2/1		

Platinum II cushion series

Dimensions

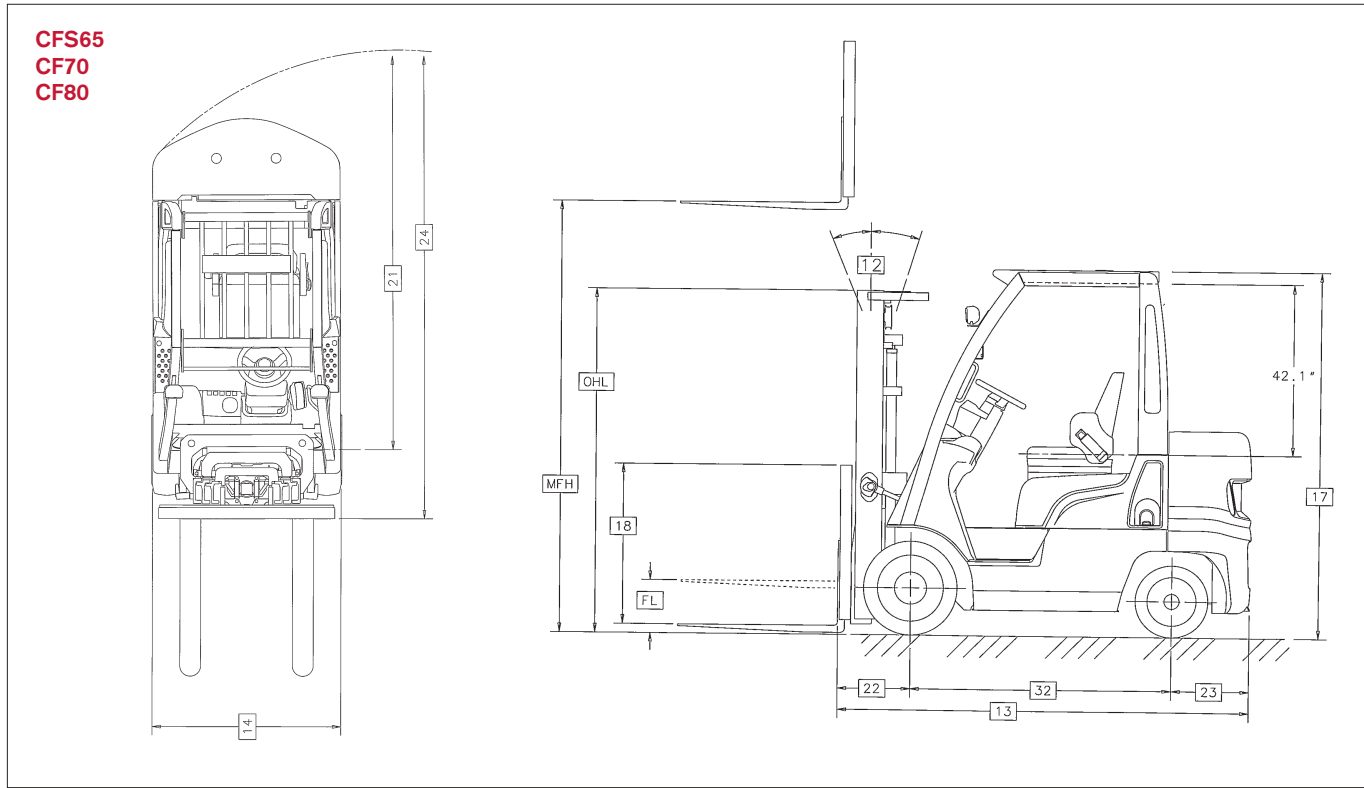

Mast Specifications & Rated Capacities

	Mast Name	Maximum Fork Height	Overall Height Lowered		Free Lift	Tilt Angle Forward/Backward	Rated Capacity at 24" Load Center		
			CFS65	CF70/CF80			CFS65	CF70	CF80
TWO STAGE TWO STAGE (Wide view 2H)	2H280	110	76.8	77.2	7.1	5/10	6500	7000	8000
	2H310	122	82.7	83.1	7.1	5/10	6500	7000	8000
	2H350	138	92.9	93.3	10.6	5/10	6500	7000	8000
	2H380	150	100.4	100.8	10.6	5/10	6500	7000	8000
	2H430	169	110.2	110.6	10.6	5/5	6500	6800	7800
TWO STAGE (Full free 2F)	2F280	110	76.9	77.2	50	5/10	6500	7000	8000
	2F310	122	82.8	83.1	55.9	5/10	6500	7000	8000
	2F350	138	93	93.3	66.1	5/10	6500	7000	8000
	2F380	150	100.5	100.8	73.6	5/10	6500	7000	7950
THREE STAGE (Full free 3F)	3F355	140	70.9	71.3	45.1	5/5	6500	6850	7850
	3F400	157	76.9	77.2	51	5/5	6300	6750	7750
	3F445	175	82.8	83.1	56.9	5/5	6100	6600	7550
	3F485	191	88.1	88.4	62.2	5/5	5900	6450	7350
	3F520	205	93	93.3	67.1	5/5	5200	6300	7200
	3F570	224	100.5	100.8	74.6	5/5	3900	4900	5600
	3F620	244	110.3	110.6	84.4	5/5	2300	2700	2800
	3F670	264	120.2	120.5	94.3	5/5	600	1100	1200
THREE STAGE OPTIVIEW™ (3V)	3V385	152	76.9	77.2	45.7	5/5	6250	6400	7300
	3V430	169	82.8	83.1	51.6	5/5	6150	6400	7300
	3V470	185	88.1	88.4	57.5	5/5	6100	6350	7250
	3V505	199	93	93.3	62.8	5/5	5900	6200	7100
	3V555	219	100.5	100.8	67.7	5/5	4900	4900	5600
	3V600	236	110.3	110.6	75.2	5/5	2650	2700	2800
	3V650	256	120.2	120.5	85	5/5	1500	1900	2000
	3V700	276	130	130.3	94.9	5/5	700	1100	1200

6,500 / 7,000 / 8,000 lb. capacities

Main Truck Specifications

CHARACTERISTICS				Nissan	Nissan	Nissan	Nissan	
1	Manufacturer's Name			Nissan	Nissan	Nissan	Nissan	1
2	Model	Model designation		CFS65	CF70	CF80	CF80 Boxcar	2
		Long model code		MCU1F2A33LV / DV	MCUG1F2F35LV / DV	MCUG1F2F36LV / DV	MCUG1F2F36LV / DV	
3	Rated Load Capacity		lb (kg)	6500 (3250)	7000 (3500)	8000 (4000)	8000 (4000)	3
4	Load Center	Distance	in (mm)	24 (500)	24 (500)	24 (500)	24 (500)	4
5	Power Type			LP - G/LP	LP - G/LP	LP - G/LP	LP - G/LP	5
6	Operator Orientation			Sit	Sit	Sit	Sit	6
7	Tire Type	Front & rear		Cushion	Cushion	Cushion	Cushion	7
8	Wheels	Number (x=driven) front/rear		2 x /2	2 x /2	2 x /2	2 x /2	8
9	Mast	Maximum fork height	in (mm)	122 (3100)	122 (3100)	122 (3100)	122 (3100)	9
		Standard freelif	in (mm)	7.1 (180)	7.1 (180)	7.1 (180)	7.1 (180)	10
11	Forks	Thickness & width	in (mm)	2 x 5 (50x125)	2 x 5 (50x125)	2 x 5 (50x125)	2 x 5 (50x125)	11
		Length	in (mm)	42 (1070)	42 (1070)	42 (1070)	42 (1070)	
12	Tilt Angle	Standard mast - fwd/back	degree	5/10	5/10	5/10	5/10	12
13	Overall Dimensions	Length (to face of forks)	in (mm)	96.3 (2445)	98.2 (2495)	100 (2540)	94.4 (2400)	13
		Width (standard tires)	in (mm)	43.9 (1115)	45.9 (1165)	45.9 (1165)	45.9 (1165)	14
		Mast lowered (OHL)	in (mm)	82.7 (2100)	83.1 (2110)	83.1 (2110)	83.1 (2110)	15
		Mast extended with LBR	in (mm)	178.5 (4535)	178.7 (4540)	178.7 (4540)	178.7 (4540)	16
		Height - top of OHG	in (mm)	82.1 (2085)	82.3 (2090)	82.3 (2090)	82.3 (2090)	17
		Height - top of standard LBR	in (mm)	48 (1220)	48 (1220)	48 (1220)	48 (1220)	18
		Width - standard carriage	in (mm)	40.2 (1020)	40.2 (1020)	40.2 (1020)	40.2 (1020)	19
20	Grade Clearance	Ramp breakover angle	tan (%)	42	44	44	44	20
		Departure angle	tan (%)	26	32	32	41	
		Approach angle	tan (%)	26	24	24	24	
21	Turning Radius	Minimum outside	in (mm)	81.5 (2070)	82.5 (2095)	83.9 (2130)	79.9 (2030)	21
22	Overhang	Front	in (mm)	17.7 (450)	17.9 (455)	17.9 (455)	17.9 (455)	22
		Rear	in (mm)	23.4 (595)	21.3 (540)	23 (585)	17.5 (446)	23
24	Min right angle stacking aisle	Add load length & clearance	in (mm)	99.2 (2520)	100.4 (2550)	101.8 (2585)	97.8 (2485)	24
25	Speeds Maximum	Travel - forward or reverse	mph (kmh)	10.6 (17)	11.5 (18.5) fwd / 9.9 (16) rev	11.5 (18.5) fwd / 9.9 (16) rev	11.5 (18.5) fwd / 9.9 (16) rev	25
		Lift - full/empty	fpm (mm/sec)	88.6/92.5 (450/470)	88.6/92.5 (450/470)	88.6/92.5 (450/470)	88.6/92.5 (450/470)	26
		Lowering - full/empty	fpm (mm/sec)	82.7/70.9 (420/360)	82.7/70.9 (420/360)	82.7/70.9 (420/360)	82.7/70.9 (420/360)	
27	Drawbar Pull Max.	LP - full load	lb (kg)	4189 (1900)	6228 (2825)	6228 (2825)	6228 (2825)	27
		LP - empty	lb (kg)	1764 (800)	2425 (1100)	2425 (1100)	2425 (1100)	
28	Gradeability Max. (1.2 mph)	LP - full/empty	tan (%)	24 / 16	38 / 18	34 / 15	34 / 15	28
29	Truck Weight	Standard truck - no load	lb (kg)	9825 (4455)	10460 (4740)	11150 (5055)	11515 (5222)	29
30	Weight Distribution	Front axle - empty	lb (kg)	2755 (1250)	3365 (1525)	3150 (1425)	3385 (1535)	30
		Rear axle - empty	lb (kg)	7070 (3205)	7095 (3215)	8000 (3630)	8130 (3687)	
		Front axle - with rated load	lb (kg)	14225 (6715)	15365 (7250)	16190 (7320)	17065 (7739)	
		Rear axle - with rated load	lb (kg)	2100 (990)	2095 (990)	2960 (1335)	2450 (1111)	
31	Tire Size	Front	in	21 x 8 x 15	22 x 9 x 16	22 x 9 x 16	22 x 9 x 16	31
		Rear	in	16.25 x 6 x 11.25	18 x 6 x 12.12	18 x 6 x 12.12	18 x 6 x 12.12	
32	Wheelbase		in (mm)	55.1 (1400)	59.1 (1500)	59.1 (1500)	59.1 (1500)	32
33	Tread - Center of Tire	Front	in (mm)	35.8 (910)	37 (940)	37 (940)	37 (940)	33
		Rear	in (mm)	35 (890)	36.6 (930)	36.6 (930)	36.6 (930)	
	Headroom	SIP to bottom of OHG	in (mm)	42.1 (1070)	42.1 (1070)	42.1 (1070)	42.1 (1070)	
	Counterweight Height		in (mm)	45.5 (1155)	46.4 (1180)	46.4 (1180)	50.4 (1280)	
	Step Height		in (mm)	16.5 (420)	17.1 (435)	17.1 (435)	17.1 (435)	
34	Ground Clearance	Under mast	in (mm)	2.8 (70)	3.1 (80)	3.1 (80)	3.1 (80)	34
		Under power unit	in (mm)	3.5 (90)	3.7 (95)	3.7 (95)	3.7 (95)	
		Under frame (WB center)	in (mm)	5.5 (140)	5.7 (145)	5.7 (145)	5.7 (145)	
35	Service Brake	Type		Drum and Shoe	Drum and Shoe	Drum and Shoe	Drum and Shoe	35
36	Parking Brake	Type		Hand	Hand	Hand	Hand	36
37	Steering	Type		Full Hydraulic	Full Hydraulic	Full Hydraulic	Full Hydraulic	37
38	Engine	Model		Nissan K25	Nissan K25	Nissan K25	Nissan K25	38
	Rated Output	SAE gross - LP	hp (kW) @ rpm	62.9 (46.9) @ 2700	62.9 (46.9) @ 2700	62.9 (46.9) @ 2700	62.9 (46.9) @ 2700	
	Rated Torque	SAE gross - LP	ft-lb (Nm) @ rpm	138.7 (188) @ 1600	138.7 (188) @ 1600	138.7 (188) @ 1600	138.7 (188) @ 1600	
	Displacement		cu in (cm ³)	151.8 (2488)	151.8 (2488)	151.8 (2488)	151.8 (2488)	
39	Transmission	Type		Automatic	Automatic	Automatic	Automatic	39
		Number speeds - fwd/rev		1/1	2/1	2/1	2/1	

Available Equipment

Standard Equipment

- Nissan's own K21 and K25 industrial engines with Electronic Concentrated Control System (ECCS)
- Electronic fuel injected technology with single-port fuel injection (LP) / multi-port injection (Gas)
- Low emission levels, well below EPA Tier II and CARB requirements
- Engine/transmission protection and warning system to safeguard your investment
- Operator Presence System includes seat-actuated power interrupt, auto-mast lock, return-to-neutral, audio and visual warnings
- Full suspension seat with Operator Restraint System, includes a non-cinching seat belt for greater comfort
- Seat belt warning system, horn, and back-up alarm
- Tilt-adjustable steering wheel with memory
- Multifunction LCD display with operator PIN security access
- Hour meter, clock, and calendar
- On-board diagnostics and programmable service reminder
- Speedometer and F/N/R transmission indicator
- Engine coolant temperature gauge and low fuel warning light (LP) / fuel gauge (Gas)
- Cushioned stability control
- Automatic transmission with drive-by-wire throttle control
- Hydrostatic power steering
- Single lift/tilt hydraulic control lever
- High air intake system combined with cyclone air filter
- Swing-out LP bracket (LP models only)
- Overhead guard mounted headlights
- 5-piece reinforced overhead guard
- One-piece, no-tool floorboard

Optional Equipment

- Ground speed control (high/low speed settings) and controlled acceleration mode
- Dual fuel engine for LP and Gasoline
- UL safety ratings available for LP fuel types*
- Swing-down LP bracket*
- Separate lift & tilt hydraulic control levers
- Fingertip controls*
- Steering wheel with spinner knob
- Swivel seat with rear OHG mounted assist grip with horn button*
- Recycler Special package
- Drive-in racking (30" at 60" / 28" at 54")*
- Extra tilt
- Open core radiator with straight fin & in-line tube design
- Radiator screen
- Diffusion exhaust muffler
- Overhead guard mounted pre-cleaner
- Rear combination light package
- Rotating beacons & strobe lights
- Rear work light

*Available on select models. Consult factory.

Technical Information **cushion models**

With features designed to exceed expectations in the areas of performance, fuel efficiency, emissions regulations, operator comfort and low cost of ownership, the Platinum II Series is the result of Nissan's relentless pursuit in achieving the perfect balance between the needs of the **Owner, Operator** and the **Environment**.

Electronic Fuel Injection Engine Technology

Platinum II Series models are powered by Nissan's own K21 (2.1 liter) and K25 (2.5 liter) electronic fuel injected industrial engines. Their Electronic Concentrated Control System (ECCS) analyzes engine performance parameters and optimizes engine operation, resulting in enhanced productivity and lower fuel consumption. This system includes three main components: Engine Control Module (ECM), Vehicle Control Module (VCM), and Multifunction LCD Display.

The ECM responds to sensor input by controlling basic engine-related functions, such as proper air/fuel ratio, torque and speed, based on the requirements of the application. The VCM monitors a number of sensors to alert the operator of changing conditions via a full range of warning indicators located on the truck's LCD display. All communication among these components occurs through a Controller Area Network (CAN) system.

Nissan's K-series engines use the same proven block design and bottom-by-pass cooling system as its predecessor, the H-series engine. These enhanced engines are specifically designed and tested for industrial applications in order to deliver all the power and torque (in the low rpm range) to meet the needs of the application. As an added safeguard for your investment, the Platinum II's K21 and K25 engines include an engine/transmission protection and warning system to reduce the speed in the event of excessive heat generation or loss of oil pressure.

Low Emission Engines

Nissan's global commitment to preserving and protecting the environment is evident in the Platinum II Series' ECCS engines, providing exceptionally low emissions levels that are well below EPA Tier II and CARB requirements. Nissan is the first lift truck manufacturer to receive EPA and CARB certification for their own line-up of industrial engines. The K21 and K25's combination of ECCS and three-way catalytic system, which includes an automotive-type closed-loop design, provides enhanced fuel economy and cleaner exhaust emissions.

Enhanced Work Environment

Several standard features are included in the Platinum II Series to deliver a more comfortable and productive work environment for the operator and those in the surrounding area. Nissan's cushioned stability control design incorporates a maintenance-free rubber dampener located between the rear axle and body to enhance lateral stability under normal driving conditions.

The Nissan K-series engines offer extremely low noise levels at the operator's ear during idle and at maximum travel speeds. An optional ground speed control feature is available to control high or low maximum speed settings, while a controlled acceleration mode adjusts throttle sensitivity to increase fuel efficiency, extend drivetrain life and reduce excessive tire wear.

The Platinum II's Operator Presence System, with seat-actuated power interrupt, incorporates a mast-lock which automatically locks lift and tilt operations when the operator leaves the seat, and a return to neutral feature to minimize forklift movement if the operator leaves

the seat while the lift truck is still in gear. This presence system also includes audible and visual warnings if either the seat belt is not engaged while in travel mode, or when the parking brake has not been applied prior to the operator exiting the compartment.

A welded metal assist grip combined with a replaceable metal traction plate that's bolted to the truck's wide, low entry step, provides the operator with sure, comfortable footing and grip for this often repeated task. Nissan's own swing-down LP bracket design uses a gas spring assist to reduce operator effort during tank replacement. This optional feature also incorporates an adjustable bracket to fit various tank sizes.*

Ease of Maintenance

No tools are required to remove the one-piece diamond tread floorboard promoting fast, simple access to hydraulic components and grease fittings. Detachable side panels* and a wide-open clamshell hood provide a roomy area for service technicians to perform their tasks. The five-piece reinforced overhead guard simplifies replacement of individual components if necessary, saving time and money. An opening in the dash panel allows for quick and easy brake fluid checks.

A new multifunction LCD display includes on-board diagnostics to keep service time low, with a service reminder in order to stay current with periodic maintenance needs. Its display design provides the operator with excellent visibility and understanding of warning indicators.

Operator Comfort and Control

A spacious operator compartment provides generous foot, leg and head room for a variety of driver sizes. A standard full suspension seat with soft touch arm pads and hip restraint provides maximum operator comfort and enhanced safety. Its low profile design offers ample head clearance, while front to back travel adjustment allows a comfortable, customized fit for nearly any operator height.

The Platinum II's, tilt-adjustable steering wheel includes a memory lever, to help the operator quickly find his or her ideal driving position, while its compact design offers enhanced control and handling. Hydrostatic power steering minimizes steer effort and operator fatigue. An optional swivel seat produces greater operator comfort and visibility while driving in reverse, and includes a rear assist grip with horn button to further enhance operator productivity and maintain greater control*. Automotive-style light and turn signal levers simplify repetitive actions allowing the operator to focus on the job. Optional features designed to enhance load handling efficiency and boost operator productivity include Nissan's exclusive three-stage OPTIVIEW™ mast, providing up to 50% greater visibility. There's also an optional auto tilt leveling system to assist proper mast/fork positioning.

Enhanced comfort results from the Platinum II Series' Operator Comfort System, which includes a full suspension seat, pedals mounted to the chassis frame, and rubber shock absorbers located throughout the vehicle to reduce vibration from the engine and transmission to the operator.

*Available on select models. Consult factory.

Option Availability

Platinum Series Cushion Models

Standard S Option O

		Fuel Types		
		LP	Gasoline ¹	Dual Fuel
Vehicle Management	Vehicle Control Module (VCM)	S	S	S
	Multifunction LCD display	S	S	S
	Security PIN access	S	S	S
	On-board diagnostics and service reminder	S	S	S
	Engine coolant temperature gauge	S	S	S
	Oil pressure, transmission fluid and coolant temperature warning light	S	S	S
	Low LP fuel warning light	S	-	S
	Gas gauge	-	S	S
Powertrain	Electronic Concentrated Control System (ECCS)	S	S	S
	Engine/transmission protection system	S	S	S
	Automatic return-to-neutral	S	S	S
	Three-way catalytic converter	S	S	S
	Cushioned stability control	S	S	S
	Ground speed control – high/low speed selector	O	O	O
	Controlled acceleration – power/economy modes	O	O	O
	Radiator screen	O	O	O
	Diffusion exhaust muffler	O	O	O
	UL Safety rating ¹	O	-	-
LP System	Swing-out LP bracket	S	-	S
	Swing-down LP bracket ²	O	-	O
Brake	Parking brake with warning buzzer	S	S	S
Mast	Seat actuated auto-mast lock system	S	S	S
	OPTIVIEW™ three-stage mast	O	O	O
Hydraulic System	Single lift/tilt control lever	S	S	S
	Separate lift & tilt control levers	O	O	O
	Auto-tilt leveling system	O	O	O
	Hydraulic load sensing valve system	S	S	S
Steering System	Tilt steering wheel with memory lock	S	S	S
	Hydrostatic power steering system	S	S	S
Operator Conveniences	Full suspension seat	S	S	S
	OHG-mounted headlights	S	S	S
	Back-up warning buzzer	S	S	S
	Rearview mirrors	O	O	O
	Rear combination light package	O	O	O
	Rear work light	O	O	O
	Strobe lights & rotating beacons	O	O	O

1. Available on select models. Consult factory. 2. Available on most LP and Dual Fuel models. Consult factory.



3000-lb, 3500-lb, 4000-lb



4000-lb, 5000-lb, 5500-lb,
6000-lb, 6500-lb



6000-lb, 7000-lb, 8000-lb



ISO 14001: 2004
NISSAN GREEN PROGRAM

Platinum II, Nissan Forklift and the Nissan Forklift logo are all registered trademarks of Nissan Forklift Corporation, North America. Nissan Forklift Corporation reserves the right to make product changes relating to colors, equipment, specifications or available options without notice. For more information, contact your Nissan Forklift representative.

NISSAN
FORKLIFT