

NISSAN
FORKLIFT

Platinum II Series

Pneumatic Tire / Engine Powered Models / LPG, Gasoline, Dual Fuel, Diesel

3,000 – 7,000 lb.
Capacities



Platinum II pneumatic series

Dimensions

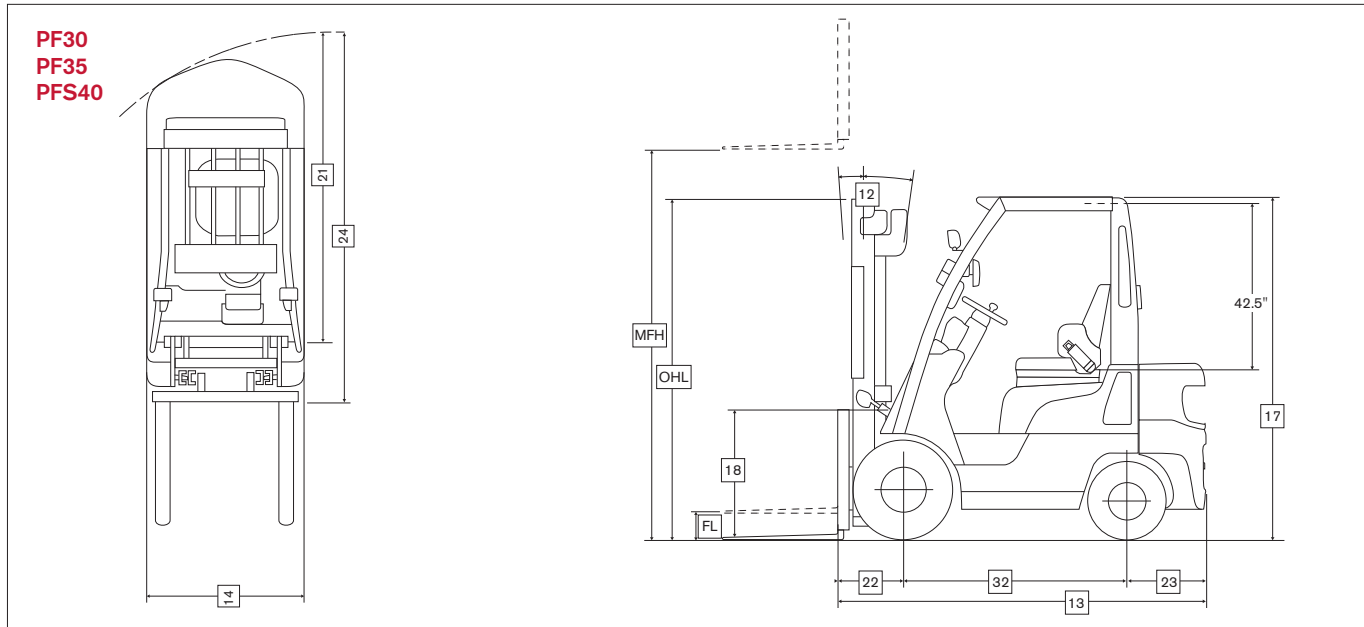

Mast Specifications & Rated Capacities

	Mast Name	Maximum Fork Height	Overall Height Lowered	Free Lift	Tilt Angle Forward/Backward	Rated Capacity at 24" Load Center		
						PF30	PF35	PFS40
TWO STAGE (Wide view 2W)	2W270	106	72.6	6.2	6/12	3000	3500	4000
	2W300	118	78.5	6.2	6/12	3000	3500	4000
	2W330	130	84.4	6.2	6/12	3000	3500	4000
	2W350	138	89.8	6.2	6/12	3000	3500	4000
	2W370	146	94.7	6.2	6/12	3000	3500	4000
	2W400	157	102.2	6.2	6/6	3000	3500	3850
	2W450	177	112.0	6.2	6/6	2900	3200	3450
	2W500	197	121.9	6.2	6/6	2650	3100	3200
TWO STAGE (Full free 2F)	2F300	118	78.5	53.6	6/10	3000	3500	4000
	2F330	130	84.4	59.5	6/10	3000	3500	4000
	2F350	138	89.8	64.8	6/10	3000	3500	4000
	2F370	146	94.7	69.8	6/10	3000	3400	3900
	2F400	157	102.2	77.2	6/6	2900	3300	3800
THREE STAGE (Full free 3F)	3F385	152	72.6	47.0	6/6	2900	3300	3850
	3F430	169	78.5	52.9	6/6	2800	3200	3550
	3F475	187	84.4	58.8	6/6	2700	3100	3450
	3F515	203	89.8	64.1	6/6	2600	2800	3150
	3F550	217	94.7	69.0	6/6	2350	2600	2700
	3F600	236	102.2	76.5	6/6	1300	1500	1800
	3F650	256	112.0	86.3	6/6	1200	1400	1700
	3F700	276	121.9	96.2	6/6	1100	1300	1600
THREE STAGE Optview (3V)	3V360	142	72.6	48.4	6/6	2900	3300	3700
	3V405	159	78.5	54.3	6/6	2800	3200	3550
	3V450	177	84.4	60.2	6/6	2700	3100	3450
	3V490	193	89.8	65.5	6/6	2600	2800	3150
	3V525	207	94.7	70.4	6/6	2350	2600	2700
	3V575	226	102.2	77.9	6/6	1300	1500	1800
	3V633	249	112	87.8	6/6	1200	1400	1700
	3V688	271	121.9	97.6	6/6	1100	1300	1600

3,000 / 3,500 / 4,000 lb. capacities

Main Truck Specifications

					Nissan	Nissan	Nissan	
CHARACTERISTICS	1	Manufacturer's name			Nissan	Nissan	Nissan	1
	2	Model	Model Designation		PF30	PF35	PFS40	2
			Long Model Code		MP1F1A15JV / LV / DV	MP1F1A18JV / LV / DV	MP1F1A20JV / LV / DV	
	3	Rated Load Capacity		lb (kg)	3000 (1500)	3500 (1750)	4000 (2000)	3
	4	Load Center	Distance	in (mm)	24 (500)	24 (500)	24 (500)	4
	5	Power Type			G - LP - G/LP	G - LP - G/LP	G - LP - G/LP	5
6	Operator Orientation			Sit	Sit	Sit	6	
DIMENSIONS	7	Tire Type	Front & rear		Pneumatic	Pneumatic	Pneumatic	7
	8	Wheels	Number (x=driven) front/rear		2 x / 2	2 x / 2	2 x / 2	8
	9	Mast	Maximum fork height	in (mm)	130 (3300)	130 (3300)	130 (3300)	9
			Standard freelif	in (mm)	6.2 (160)	6.2 (160)	6.2 (160)	10
	11	Forks	Thickness & width	in (mm)	1.5 x 4 (40x100)	1.5 x 4 (40x100)	1.5 x 4 (40x100)	11
			Length	in (mm)	42 (1070)	42 (1070)	42 (1070)	
	12	Tilt Angle	Standard mast - fwd/back	degree	6/12	6/12	6/12	12
	13	Overall Dimensions	Length (to face of forks)	in (mm)	89.0 (2260)	90.2 (2290)	91.3 (2320)	13
			Width (standard tires)	in (mm)	41.9 (1065)	41.9 (1065)	41.9 (1065)	14
			Mast lowered (OHL)	in (mm)	84.4 (2145)	84.4 (2145)	84.4 (2145)	15
			Mast extended with LBR	in (mm)	179.3 (4555)	179.3 (4555)	179.3 (4555)	16
			Height - top of OHG	in (mm)	83.3 (2115)	83.3 (2115)	83.3 (2115)	17
			Height - top of standard LBR	in (mm)	48 (1220)	48 (1220)	48 (1220)	18
			Width - standard carriage	in (mm)	36.2 (920)	36.2 (920)	36.2 (920)	19
	20	Grade Clearance	Ramp breakover angle	tan (%)	49	49	49	20
			Departure angle	tan (%)	39	37	35	
			Approach angle	tan (%)	37	37	37	
	21	Turning Radius	Minimum outside	in (mm)	76.2 (1935)	77.6 (1970)	79.1 (2010)	21
	22	Overhang	Front	in (mm)	15.7 (400)	15.7 (400)	15.7 (400)	22
Rear			in (mm)	18.1 (460)	19.3 (490)	20.5 (520)	23	
24	Min Right Angle Stack	Add load length & clearance	in (mm)	91.9 (2335)	93.3 (2370)	94.9 (2410)	24	
PERFORMANCE	25	Speeds Maximum	Travel - forward or reverse	mph (kmh)	11.5 (18.5)	11.5 (18.5)	11.5 (18.5)	25
	26		Lift - full/empty	fpm (mm/sec)	122/127.9 (620/650)	122/127.9 (620/650)	122/127.9 (620/650)	26
			Lowering - full/empty	fpm (mm/sec)	98.4 (500)	98.4 (500)	98.4 (500)	
	27	Drawbar Pull Max	Full load	lb (kg)	3705 (1680)	3705 (1680)	3705 (1680)	27
Empty			lb (kg)	2470 (1120)	2646 (1200)	2932 (1330)		
28	Gradeability Max (1.2 mph)	Full/empty	tan (%)	31 / 28	38 / 24	33 / 21	28	
WEIGHT	29	Truck Weight	Standard truck - no load	lb (kg)	5810 (2635)	6175 (2800)	6505 (2950)	29
	30	Weight Distribution	Front axle - empty	lb (kg)	2540 (1150)	2440 (1105)	2340 (1060)	30
			Rear axle - empty	lb (kg)	3270 (1485)	3735 (1695)	4165 (1890)	
			Front axle - with rated load	lb (kg)	7710 (3620)	8475 (3985)	9235 (4350)	
			Rear axle - with rated load	lb (kg)	1100 (515)	1200 (565)	1270 (600)	
CHASSIS & WHEELS	31	Tire Size	Front	in	6.50-10-10PR	6.50-10-10PR	6.50-10 Solid	31
			Rear	in	5.00-8-8-PR	5.00-8-8-PR	5.00-8 Solid	
	32	Wheelbase		in (mm)	55.1(1400)	55.1(1400)	55.1(1400)	32
	33	Tread - Center of Tire	Front / rear	in (mm)	35/35.4 (890/900)	35/35.4 (890/900)	35/35.4 (890/900)	33
			Front dual tires	in (mm)	43.1 (1095)	43.1 (1095)	43.1 (1095)	
		Headroom	SIP to bottom of OHG	in (mm)	42.5 (1080)	42.5 (1080)	42.5 (1080)	
		Counterweight Height		in (mm)	41.9 (1065)	41.9 (1065)	41.9 (1065)	
		Step Height		in (mm)	17.7 (450)	17.7 (450)	17.7 (450)	
	34	Ground Clearance	Under mast	in (mm)	4.5 (115)	4.5 (115)	4.5 (115)	34
			Under power unit	in (mm)	5.3 (135)	5.3 (135)	5.3 (135)	
Under frame (WB center)			in (mm)	5.9 (150)	5.9 (150)	5.9 (150)		
35	Service Brake	Type		Drum and Shoe	Drum and Shoe	Drum and Shoe	35	
36	Parking Brake	Type		Hand	Hand	Hand	36	
37	Steering	Type		Full Hydraulic	Full Hydraulic	Full Hydraulic	37	
DRIVE LINE	38	Engine	Manufacturer / Model		Nissan K21	Nissan K21	Nissan K21	38
		Rated Output	SAE gross	hp (kW) @ rpm	55 (41) @ 2700	55 (41) @ 2700	55 (41) @ 2700	
		Rated Torque	SAE gross	ft-lb (Nm) @ rpm	111.4 (151) @ 2000	111.4 (151) @ 2000	111.4 (151) @ 2000	
		Displacement		cu in (cm ³)	126 (2065)	126 (2065)	126 (2065)	
	39	Transmission	Type		Automatic	Automatic	Automatic	39
			Number speeds - fwd/rev		1/1	1/1	1/1	

Platinum II pneumatic series

Dimensions

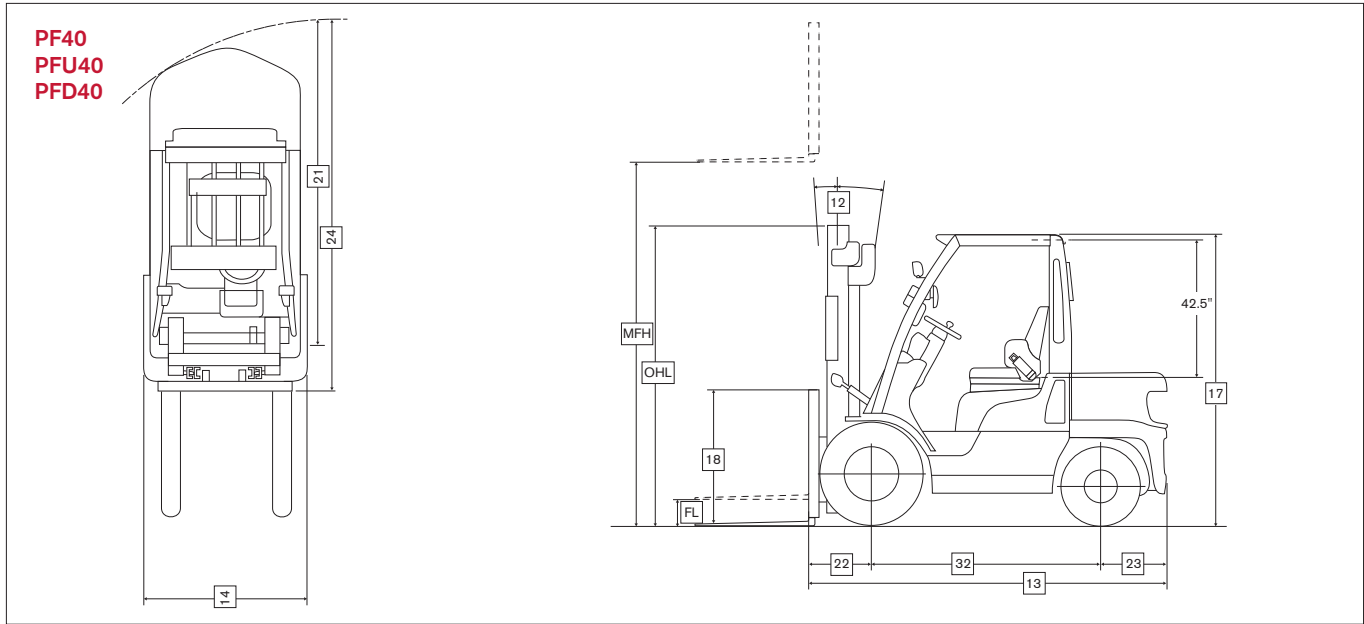

Mast Specifications & Rated Capacities

	Mast Name	Maximum Fork Height	Overall Height Lowered	Free Lift	Tilt Angle Forward/Backward	Rated Capacity at 24" Load Center
TWO STAGE (Wide view 2W)	2W270	106	72.6	6.1	6/12	4000
	2W300	118	78.5	6.1	6/12	4000
	2W330	130	84.4	6.1	6/12	4000
	2W350	138	89.8	6.1	6/12	4000
	2W370	146	94.7	6.1	6/12	4000
	2W400	157	102.2	6.1	6/6	4000
	2W450	177	112.0	6.1	6/6	3850
	2W500	197	121.9	6.1	6/6	3450
TWO STAGE (Full free 2F)	2F300	118	78.5	53.5	6/12	4000
	2F330	130	84.4	59.4	6/12	4000
	2F350	138	89.8	64.7	6/12	4000
	2F370	146	94.7	69.6	6/12	4000
	2F400	157	102.2	77.1	6/6	3950
THREE STAGE (Full free 3F)	3F385	152	72.6	47.2	6/6	4000
	3F430	169	78.5	53.1	6/6	3850
	3F475	187	84.4	59.0	6/6	3700
	3F515	203	89.8	64.3	6/6	3300
	3F550	217	94.7	69.2	6/6	2950
	3F600	236	102.2	76.7	6/6	1900
	3F650	256	112	86.5	6/6	1800
	3F700	276	121.9	96.4	6/6	700
THREE STAGE Optiview (3V)	3V360	142	72.8	47.2	6/6	3900
	3V405	159	78.7	53.1	6/6	3700
	3V450	177	84.6	59.0	6/6	3600
	3V490	193	90	64.3	6/6	3300
	3V525	207	94.9	69.2	6/6	3000
	3V575	226	102.4	76.7	6/6	2500
	3V633	249	112.2	86.5	6/6	2300
	3V688	271	122	96.4	6/6	1900

4,000 lb. capacity

Main Truck Specifications

					Nissan	Nissan	Nissan	
CHARACTERISTICS	1	Manufacturer's Name			Nissan	Nissan	Nissan	1
	2	Model	Model designation		PF40	PFU40	PFD40	2
			Long model code		MP1F2A20JV / LV / DV	MU1F2A20JV / LV / DV	MY1F2A20V	
	3	Rated Load Capacity		lb (kg)	4000 (2000)	4000 (2000)	4000 (2000)	3
	4	Load Center	Distance	in (mm)	24 (500)	24 (500)	24 (500)	4
	5	Power Type			G - LP - G/LP	G - LP - G/LP	Diesel	5
6	Operator Orientation			Sit	Sit	Sit	6	
DIMENSIONS	7	Tire Type	Front & rear		Pneumatic	Pneumatic	Pneumatic	7
	8	Wheels	Number (x=driven) front/rear		2 x / 2	2 x / 2	2 x / 2	8
	9	Mast	Maximum fork height	in (mm)	130 (3300)	130 (3300)	130 (3300)	9
			Standard freelif	in (mm)	6.1 (155)	6.1 (155)	6.1 (155)	10
	11	Forks	Thickness & width	in (mm)	1.5 x 4 (40x100)	1.5 x 4 (40x100)	1.5 x 4 (40x100)	11
			Length	in (mm)	42 (1070)	42 (1070)	42 (1070)	
	12	Tilt Angle	Standard mast - fwd/back	degree	6/12	6/12	6/12	12
	13	Overall Dimensions	Length (to face of forks)	in (mm)	96.9 (2460)	96.9 (2460)	96.9 (2460)	13
			Width (standard tires)	in (mm)	45.3 (1150)	45.3 (1150)	45.3 (1150)	14
			Mast lowered (OHL)	in (mm)	84.4 (2145)	84.4 (2145)	84.4 (2145)	15
			Mast extended with LBR	in (mm)	179.3 (4555)	179.3 (4555)	179.3 (4555)	16
			Height - top of OHG	in (mm)	83.5 (2120)	83.5 (2120)	83.5 (2120)	17
			Height - top of standard LBR	in (mm)	48 (1220)	48 (1220)	48 (1220)	18
	20	Grade Clearance	Ramp breakover angle	tan (%)	44	44	44	20
			Departure angle	tan (%)	45	45	45	
			Approach angle	tan (%)	32	32	32	
	21	Turning Radius	Minimum outside	in (mm)	83.5 (2120)	83.5 (2120)	83.5 (2120)	21
	22	Overhang	Front	in (mm)	17.5 (445)	17.5 (445)	17.5 (445)	22
			Rear	in (mm)	16.3 (415)	16.3 (415)	16.3 (415)	23
24	Min right angle stacking aisle	Add load length & clearance	in (mm)	101 (2565)	101 (2565)	101 (2565)	24	
PERFORMANCE	25	Speeds Maximum	Travel - forward or reverse	mph (kmh)	11.8 (19)	11.8 (19)	11.8 (19)	25
			Lift - full/empty	fpm (mm/sec)	118.1/127.9 (600/650)	129.9/137.8 (660/700)	127.9/137.8(650/700)	26
			Lowering - full/empty	fpm (mm/sec)	98.4 (500)	98.4 (500)	98.4 (500)	
	27	Drawbar Pull Maximum	Full load	lb (kg)	3880 (1760)	4189 (1900)	4542(2060)	27
Empty			lb (kg)	3439 (1560)	3439 (1560)	3616 (1640)		
28	Gradeability Max (1.2 mph)	Full/empty	tan (%)	31 / 28	39 / 28	36 / 28	28	
WEIGHT	29	Truck Weight	Standard truck - no load	lb (kg)	7145 (3240)	7145 (3240)	7400 (3355)	29
	30	Weight Distribution	Front axle - empty	lb (kg)	3365 (1525)	3365 (1525)	3440 (1560)	30
			Rear axle - empty	lb (kg)	3780 (1715)	3780 (1715)	3960 (1795)	
			Front axle - with rated load	lb (kg)	10015 (4709)	10015 (4709)	10095 (4740)	
			Rear axle - with rated load	lb (kg)	1130 (531)	1130 (531)	1305 (615)	
CHASSIS & WHEELS	31	Tire Size	Front	in	7.00-12-12PR	7.00-12-12PR	7.00-12-12PR	31
			Rear	in	6.00-9-10PR	6.00-9-10PR	6.00-9-10PR	
	32	Wheelbase		in (mm)	63 (1600)	63 (1600)	63 (1600)	32
	33	Tread - Center of Tire	Front / rear	in (mm)	37.8/38.4 (960/975)	37.8/38.4 (960/975)	37.8/38.4 (960/975)	33
			Front dual tires	in (mm)	47.4 (1205)	47.4 (1205)	47.4 (1205)	
		Headroom	SIP to bottom of OHG	in (mm)	42.5 (1080)	42.5 (1080)	42.5 (1080)	
		Counterweight Height		in (mm)	42.1 (1070)	42.1 (1070)	42.1 (1070)	
		Step Height		in (mm)	17.9 (455)	17.9 (455)	17.9 (455)	
	34	Ground Clearance	Under mast	in (mm)	4.5 (115)	4.5 (115)	4.5 (115)	34
			Under power unit	in (mm)	5.3 (135)	5.3 (135)	5.3 (135)	
			Under frame (WB center)	in (mm)	6.1 (155)	6.1 (155)	6.1 (155)	
35	Service Brake	Type		Drum and Shoe	Drum and Shoe	Drum and Shoe	35	
36	Parking Brake	Type		Hand	Hand	Hand	36	
DRIVE LINE	37	Steering	Type		Full Hydraulic	Full Hydraulic	Full Hydraulic	37
	38	Engine	Model		Nissan K21	Nissan K25	Nissan QD32	38
		Rated Output	SAE gross	hp (kW) @ rpm	55 (41) @ 2700	62.9 (46.9) @ 2700	55 (41) @ 2000	
		Rated Torque	SAE gross	ft-lb (Nm) @ rpm	111.4 (151) @ 2000	138.7 (188) @ 1600	143.8 (195) @ 1800	
		Displacement		cu in (cm ³)	126 (2065)	151.8 (2488)	192.4 (3153)	
	39	Transmission	Type		Automatic	Automatic	Automatic	39
Number speeds - fwd/rev				1/1	1/1	1/1		

Platinum II pneumatic series

Dimensions

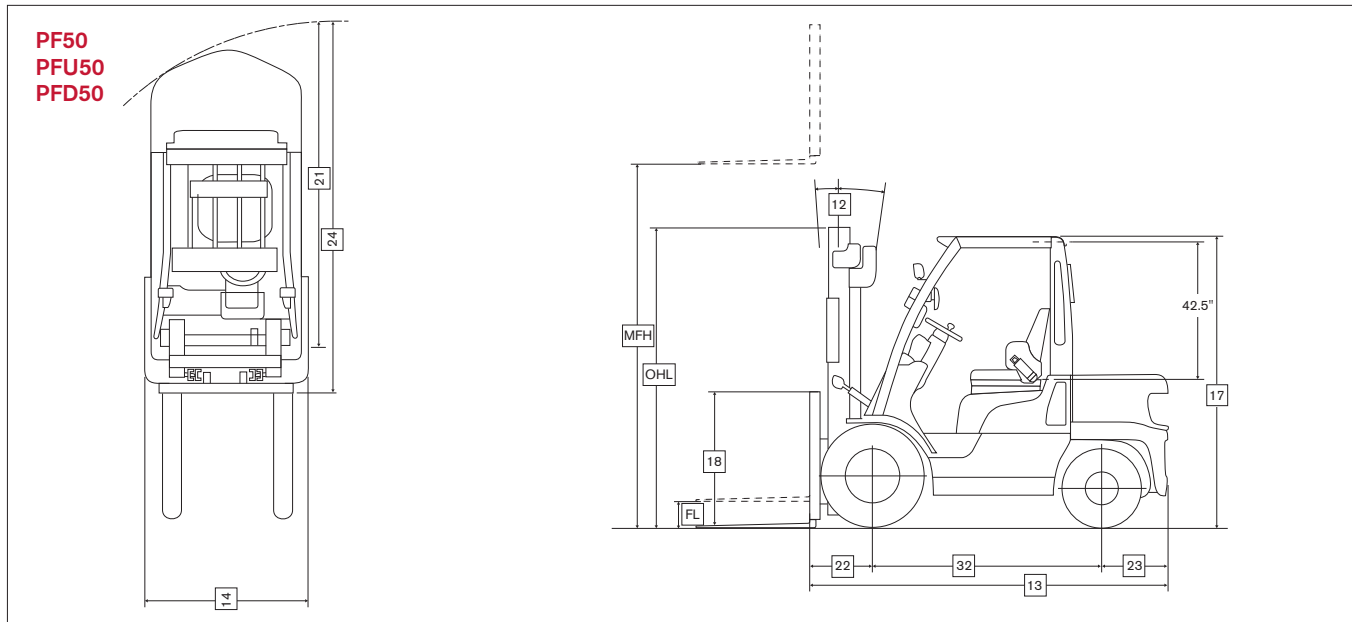

Mast Specifications & Rated Capacities

	Mast Name	Maximum Fork Height	Overall Height Lowered	Free Lift	Tilt Angle Forward/Backward	Rated Capacity at 24" Load Center
TWO STAGE (Wide view 2W)	2W270	106	72.6	6.1	6/12	5000
	2W300	118	78.5	6.1	6/12	5000
	2W330	130	84.4	6.1	6/12	5000
	2W350	138	89.8	6.1	6/12	5000
	2W370	146	94.7	6.1	6/12	5000
	2W400	157	102.2	6.1	6/6	5000
	2W450	177	112.0	6.1	6/6	4400
	2W500	197	121.9	6.1	6/6	3700
TWO STAGE (Full free 2F)	2F300	118	78.5	53.5	6/12	5000
	2F330	130	84.4	59.4	6/12	5000
	2F350	138	89.8	64.7	6/12	5000
	2F370	146	94.7	69.6	6/12	5000
	2F400	157	102.2	77.1	6/6	4950
THREE STAGE (Full free 3F)	3F385	152	72.6	47.2	6/6	5000
	3F430	169	78.5	53.1	6/6	4700
	3F475	187	84.4	59.0	6/6	4300
	3F515	203	89.8	64.3	6/6	3650
	3F550	217	94.7	69.2	6/6	3350
	3F600	236	102.2	76.7	6/6	2100
	3F650	256	112	86.5	6/6	2000
	3F700	276	121.9	96.4	6/6	700
THREE STAGE Optiview (3V)	3V360	142	72.8	47.2	6/6	4900
	3V405	159	78.7	53.1	6/6	4700
	3V450	177	84.6	59.0	6/6	4300
	3V490	193	90	64.3	6/6	3900
	3V525	207	94.9	69.2	6/6	3500
	3V575	226	102.4	76.7	6/6	3000
	3V633	249	112.2	86.5	6/6	2600
	3V688	271	122	96.4	6/6	2300

5,000 lb. capacity

Main Truck Specifications

					Nissan	Nissan	Nissan	
CHARACTERISTICS	1	Manufacturer's Name			Nissan	Nissan	Nissan	1
	2	Model	Model designation		PF50	PFU50	PFD50	2
			Long model code		MP1F2A25JV / LV / DV	MU1F2A25JV / LV / DV	MY1F2A25V	
	3	Rated Load Capacity		lb (kg)	5000 (2500)	5000 (2500)	5000 (2500)	3
	4	Load Center	Distance	in (mm)	24 (500)	24 (500)	24 (500)	4
	5	Power Type			G - LP - G/LP	G - LP - G/LP	Diesel	5
6	Operator Orientation			Sit	Sit	Sit	6	
DIMENSIONS	7	Tire Type	Front & rear		Pneumatic	Pneumatic	Pneumatic	7
	8	Wheels	Number (x=driven) front/rear		2 x / 2	2 x / 2	2 x / 2	8
	9	Mast	Maximum fork height	in (mm)	130 (3300)	130 (3300)	130 (3300)	9
			Standard freelif	in (mm)	6.1 (155)	6.1 (155)	6.1 (155)	10
	11	Forks	Thickness & width	in (mm)	1.5 x 4 (40x100)	1.5 x 4 (40x100)	1.5 x 4 (40x100)	11
			Length	in (mm)	42 (1070)	42 (1070)	42 (1070)	
	12	Tilt Angle	Standard mast - fwd/back	degree	6/12	6/12	6/12	12
	13	Overall Dimensions	Length (to face of forks)	in (mm)	99 (2515)	99 (2515)	99 (2515)	13
			Width (standard tires)	in (mm)	45.3 (1150)	45.3 (1150)	45.3 (1150)	14
			Mast lowered (OHL)	in (mm)	84.4 (2145)	84.4 (2145)	84.4 (2145)	15
			Mast extended with LBR	in (mm)	179.3 (4555)	179.3 (4555)	179.3 (4555)	16
			Height - top of OHG	in (mm)	83.5 (2120)	83.5 (2120)	83.5 (2120)	17
			Height - top of standard LBR	in (mm)	48 (1220)	48 (1220)	48 (1220)	18
	20	Grade Clearance	Ramp breakover angle	tan (%)	44	44	44	20
			Departure angle	tan (%)	37	37	37	
			Approach angle	tan (%)	32	32	32	
	21	Turning Radius	Minimum outside	in (mm)	85.8 (2180)	85.8 (2180)	85.8 (2180)	21
	22	Overhang	Front	in (mm)	17.5 (445)	17.5 (445)	17.5 (445)	22
			Rear	in (mm)	18.5 (470)	18.5 (470)	18.5 (470)	23
24	Min right angle stacking aisle	Add load length & clearance	in (mm)	103.3 (2625)	103.3 (2625)	103.3 (2625)	24	
PERFORMANCE	25	Speeds Maximum	Travel - forward or reverse	mph (kmh)	11.8 (19)	11.8 (19)	11.8 (19)	25
			Lift - full/empty	fpm (mm/sec)	118.1/127.9 (600/650)	129.9/137.8 (660/700)	127.9/137.8 (650/700)	26
			Lowering - full/empty	fpm (mm/sec)	98.4 (500)	98.4 (500)	98.4 (500)	
	27	Drawbar Pull Maximum	Full load	lb (kg)	3880 (1760)	4189 (1900)	4542 (2060)	27
Empty			lb (kg)	3439 (1560)	3439 (1560)	3858 (1750)		
28	Gradeability Max (1.2 mph)	Full/empty	tan (%)	27 / 24	33 / 24	31 / 24	28	
WEIGHT	29	Truck Weight	Standard truck - no load	lb (kg)	7925 (3595)	7925 (3595)	8180 (3710)	29
	30	Weight Distribution	Front axle - empty	lb (kg)	3200 (1450)	3200 (1450)	3275 (1485)	30
			Rear axle - empty	lb (kg)	4725 (2145)	4725 (2145)	4905 (2225)	
			Front axle - with rated load	lb (kg)	11515 (5430)	11515 (5430)	11595 (5465)	
			Rear axle - with rated load	lb (kg)	1410 (665)	1410 (665)	1585 (745)	
CHASSIS & WHEELS	31	Tire Size	Front	in	7.00-12-12PR	7.00-12-12PR	7.00-12-12PR	31
			Rear	in	6.00-9-10PR	6.00-9-10PR	6.00-9-10PR	
	32	Wheelbase		in (mm)	63 (1600)	63 (1600)	63 (1600)	32
	33	Tread - Center of Tire	Front / rear	in (mm)	37.8/38.4 (960/975)	37.8/38.4 (960/975)	37.8/38.4 (960/975)	33
			Front dual tires	in (mm)	47.4 (1205)	47.4 (1205)	47.4 (1205)	
		Headroom	SIP to bottom of OHG	in (mm)	42.5 (1080)	42.5 (1080)	42.5 (1080)	
		Counterweight Height		in (mm)	42.1 (1070)	42.1 (1070)	42.1 (1070)	
		Step Height		in (mm)	17.9 (455)	17.9 (455)	17.9 (455)	
	34	Ground Clearance	Under mast	in (mm)	4.5 (115)	4.5 (115)	4.5 (115)	34
			Under power unit	in (mm)	5.3 (135)	5.3 (135)	5.3 (135)	
			Under frame (WB center)	in (mm)	6.1 (155)	6.1 (155)	6.1 (155)	
35	Service Brake	Type		Drum and Shoe	Drum and Shoe	Drum and Shoe	35	
36	Parking Brake	Type		Hand	Hand	Hand	36	
DRIVE LINE	37	Steering	Type		Full Hydraulic	Full Hydraulic	Full Hydraulic	37
	38	Engine	Model		Nissan K21	Nissan K25	Nissan QD32	38
		Rated Output	SAE gross	hp (kW) @ rpm	55 (41) @ 2700	62.9 (46.9) @ 2700	55 (41) @ 2000	
		Rated Torque	SAE gross	ft-lb (Nm) @ rpm	111.4 (151) @ 2000	138.7 (188) @ 1600	143.8 (195) @ 1800	
		Displacement		cu in (cm ³)	126 (2065)	151.8 (2488)	192.4 (3153)	
	39	Transmission	Type		Automatic	Automatic	Automatic	39
Number speeds - fwd/rev				1/1	1/1	1/1		

Platinum II pneumatic series

Dimensions

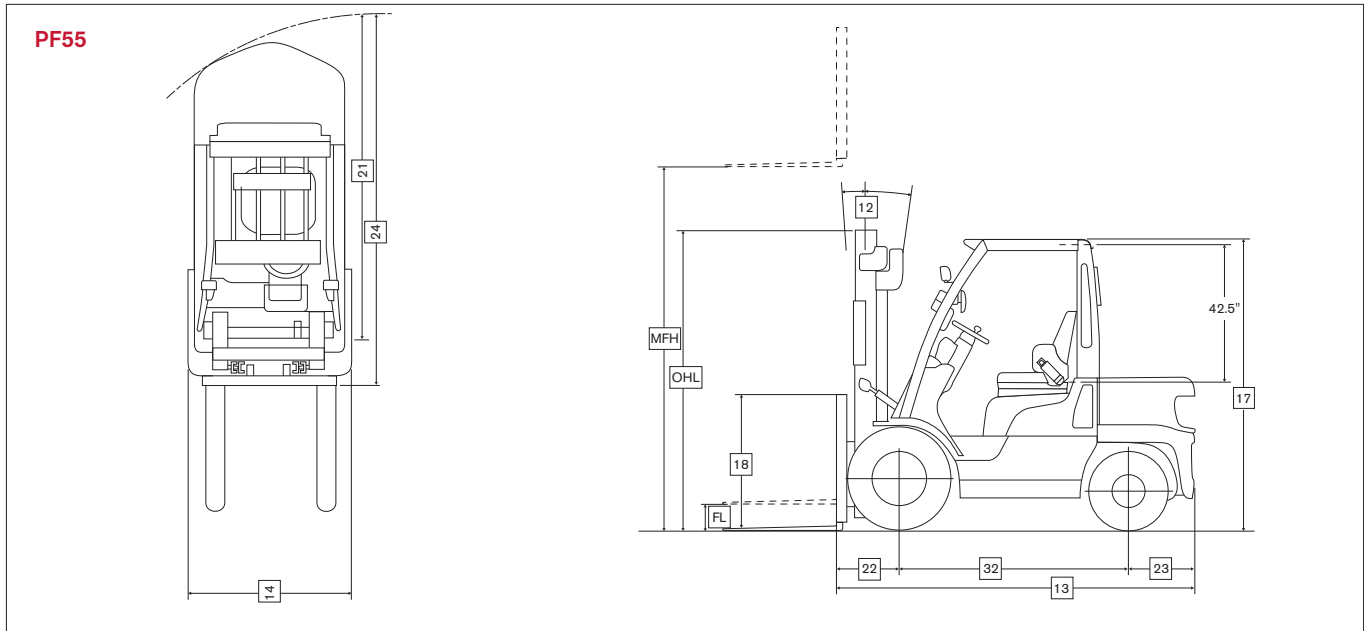

Mast Specifications & Rated Capacities

	Mast Name	Maximum Fork Height	Overall Height Lowered	Free Lift	Tilt Angle Forward/Backward	Rated Capacity at 24" Load Center
TWO STAGE (Wide view 2W)	2W270	106	73.8	6.1	6/12	5500
	2W300	118	79.7	6.1	6/12	5500
	2W330	130	85.6	6.1	6/12	5500
	2W350	138	90.9	6.1	6/12	5500
	2W370	146	95.9	6.1	6/12	5500
	2W400	157	103.3	6.1	6/6	5500
	2W450	177	113.2	6.1	6/6	5300
	2W500	197	123	6.1	6/6	4300
TWO STAGE (Full free 2F)	2F300	118	79.7	53.8	6/12	5500
	2F330	130	85.6	59.7	6/12	5500
	2F350	138	90.9	65.1	6/12	5500
	2F370	146	95.9	70	6/12	5500
	2F400	157	103.3	77.5	6/6	5500
THREE STAGE (Full free 3F)	3F385	152	79.7	55.7	6/6	5500
	3F430	169	85.6	61.6	6/6	5300
	3F475	187	90.9	66.9	6/6	5100
	3F515	203	95.9	71.8	6/6	4000
	3F550	217	103.3	79.3	6/6	3200
	3F600	236	113.2	89.1	6/6	2300
	3F650	256	123	99	6/6	1100
	3F700	276	132.9	108.8	6/6	550
THREE STAGE Optiview (3V)	3V385	152	79.7	55.7	6/6	5450
	3V430	169	85.6	61.6	6/6	5300
	3V470	185	90.9	66.9	6/6	5000
	3V505	199	95.9	71.8	6/6	3750
	3V555	219	103.3	79.3	6/6	2800
	3V600	236	113.2	89.1	6/6	1850
	3V650	256	123	99	6/6	1200
	3V700	276	132.9	108.8	6/6	650

5,500 lb. capacity

Main Truck Specifications

CHARACTERISTICS	1	Manufacturer's Name			Nissan	1
	2	Model	Model designation		PF55	2
			Long model code		MUJ1F2A28JV / LV / DV	
	3	Rated Load Capacity		lb (kg)	5500 (2750)	3
	4	Load Center	Distance	in (mm)	24 (500)	4
	5	Power Type			G - LP - G/LP	5
6	Operator Orientation			Sit	6	
DIMENSIONS	7	Tire Type	Front & rear		Pneumatic	7
	8	Wheels	Number (x=driven) front/rear		2 x / 2	8
	9	Mast	Maximum fork height	in (mm)	130 (3300)	9
			Standard freelif	in (mm)	6.1 (155)	10
	11	Forks	Thickness & width	in (mm)	1.5 x 4 (40x100)	11
			Length	in (mm)	42 (1070)	
	12	Tilt Angle	Standard mast - fwd/back	degree	6/12	12
	13	Overall Dimensions	Length (to face of forks)	in (mm)	102.8 (2610)	13
			Width (standard tires)	in (mm)	49.2 (1250)	14
			Mast lowered (OHL)	in (mm)	85.6 (2175)	15
			Mast extended with LBR	in (mm)	179.3 (4555)	16
			Height - top of OHG	in (mm)	84.6 (2150)	17
			Height - top of standard LBR	in (mm)	48 (1220)	18
	20	Grade Clearance	Ramp breakover angle	tan (%)	52	20
			Departure angle	tan (%)	42	
			Approach angle	tan (%)	41	
	21	Turning Radius	Minimum outside	in (mm)	88.2 (2240)	21
	22	Overhang	Front	in (mm)	18.5 (470)	22
			Rear	in (mm)	20.5 (520)	23
24	Min right angle stacking aisle	Add load length & clearance	in (mm)	106.7 (2710)	24	
PERFORMANCE	25	Speeds Maximum	Travel - forward or reverse	mph (kmh)	11.8 (19)	25
			Lift - full/empty	fpm (mm/sec)	104.3/114.1 (530/580)	26
			Lowering - full/empty	fpm (mm/sec)	98.4 (500)	
	27	Drawbar Pull Maximum	Full load	lb (kg)	4189 (1900)	27
Full empty			lb (kg)	4057 (1840)		
28	Gradeability Max (1.2 mph)	Full/empty	tan (%)	30 / 25	28	
WEIGHT	29	Truck Weight	Standard truck - no load	lb (kg)	8825 (4000)	29
	30	Weight Distribution	Front axle - empty	lb (kg)	3395 (1540)	30
			Rear axle - empty	lb (kg)	5430 (2460)	
			Front axle - with rated load	lb (kg)	12590 (5935)	
			Rear axle - with rated load	lb (kg)	1735 (815)	
CHASSIS & WHEELS	31	Tire Size	Front	in	28 x 9-15-12PR	31
			Rear	in	6.50-10-10PR	
	32	Wheelbase		in (mm)	63.8 (1620)	32
	33	Tread - Center of Tire	Front / rear	in (mm)	40.6/38.6 (1030/980)	33
			Front dual tires	in (mm)	47.6 (1210)	
		Headroom	SIP to bottom of OHG	in (mm)	42.5 (1080)	
		Counterweight Height		in (mm)	43.3 (1100)	
		Step Height		in (mm)	19.1 (485)	
	34	Ground Clearance	Under mast	in (mm)	5.7 (145)	34
			Under power unit	in (mm)	6.5 (165)	
Under frame (WB center)			in (mm)	7.3 (185)		
35	Service Brake	Type		Drum and Shoe	35	
36	Parking Brake	Type		Hand	36	
37	Steering	Type		Full Hydraulic	37	
DRIVE LINE	38	Engine	Model		Nissan K25	38
		Rated Output	SAE gross	hp (kW) @ rpm	62.9 (46.9) @ 2700	
		Rated Torque	SAE gross	ft-lb (Nm) @ rpm	138.7 (188) @ 1600	
		Displacement		cu in (cm ³)	151.8 (2488)	
	39	Transmission	Type		Automatic	39
Number speeds - fwd/rev				1/1		

Platinum II pneumatic series

Dimensions

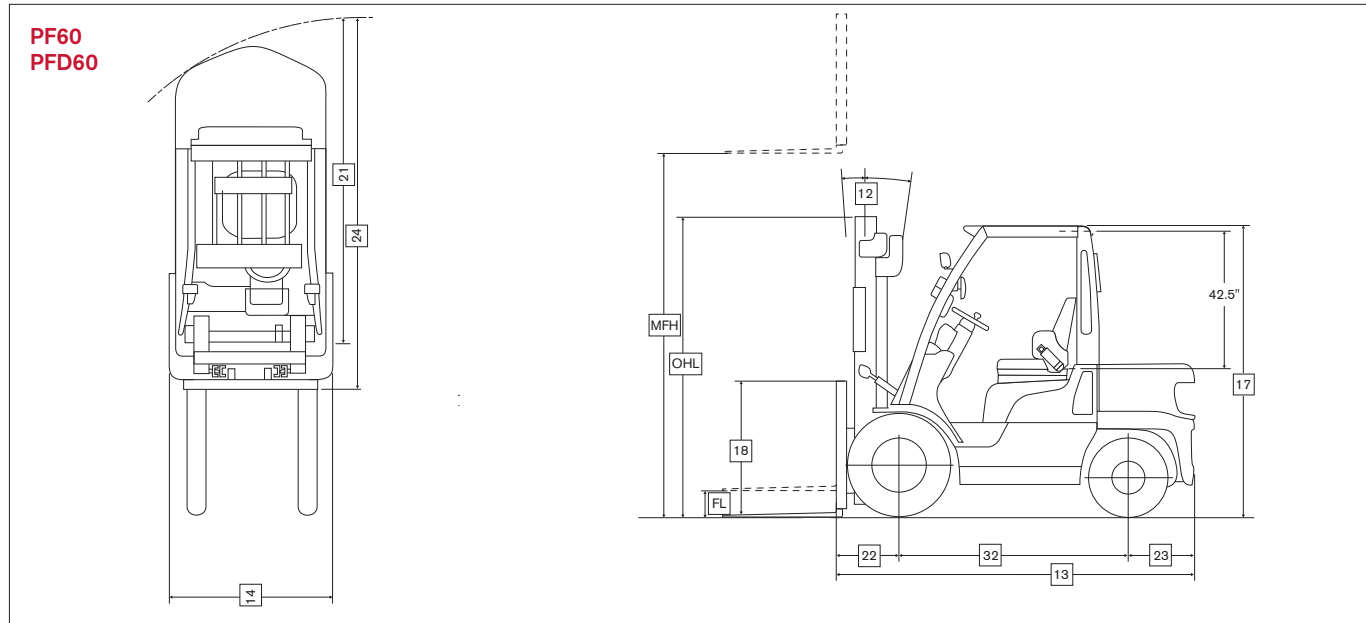

Mast Specifications & Rated Capacities

	Mast Name	Maximum Fork Height	Overall Height Lowered	Free Lift	Tilt Angle Forward/Backward	Rated Capacity at 24" Load Center
TWO STAGE (Wide view 2W)	2W270	106	73.8	6.5	6/12	6000
	2W300	118	79.7	6.5	6/12	6000
	2W330	130	85.6	6.5	6/12	6000
	2W350	138	90.9	6.5	6/12	6000
	2W370	146	95.9	6.5	6/12	6000
	2W400	157	103.3	6.5	6/6	6000
	2W450	177	113.2	6.5	6/6	5600
	2W500	197	123	6.5	6/6	5150
TWO STAGE (Full free 2F)	2F300	118	79.7	53.4	6/12	6000
	2F330	130	85.6	59.3	6/12	6000
	2F350	138	90.9	64.6	6/12	6000
	2F370	146	95.9	70	6/12	6000
	2F400	157	103.3	77	6/6	5950
THREE STAGE (Full free 3F)	3F385	152	79.7	54.8	6/6	6000
	3F430	169	85.6	60.7	6/6	5800
	3F475	187	90.9	66	6/6	5600
	3F515	203	95.9	70.9	6/6	4700
	3F550	217	103.3	78.4	6/6	3700
	3F600	236	113.2	88.2	6/6	2650
	3F650	256	123	98.1	6/6	1500
	3F700	276	132.9	107.9	6/6	1000
THREE STAGE Optiview (3V)	3V385	152	79.7	54.8	6/6	5950
	3V430	169	85.6	60.7	6/6	5750
	3V470	185	90.9	66	6/6	5500
	3V505	199	95.9	70.9	6/6	4700
	3V555	219	103.3	78.4	6/6	3700
	3V600	236	113.2	88.2	6/6	2600
	3V650	256	123	98.1	6/6	1400
	3V700	276	132.9	107.9	6/6	1000

6,000 lb. capacity

Main Truck Specifications

				Nissan	Nissan		
CHARACTERISTICS	1	Manufacturer's Name		Nissan	Nissan	1	
	2	Model	Model designation	PF60	PFD60	2	
			Long model code	MUG1F2A30JV/LV/DV	MYG1F2A30V		
	3	Rated Load Capacity		6000 (3000)	6000 (3000)	3	
	4	Load Center	Distance	24 (500)	24 (500)	4	
	5	Power Type		G - LP - G/LP	Diesel	5	
6	Operator Orientation		Sit	Sit	6		
DIMENSIONS	7	Tire Type	Front & rear	Pneumatic	Pneumatic	7	
	8	Wheels	Number (x=driven) front/rear	2 x / 2	2 x / 2	8	
	9	Mast	Maximum fork height	130 (3300)	130 (3300)	9	
			Standard freelif	6.5 (165)	6.5 (165)	10	
	11	Forks	Thickness & width	2 x 5 (50 x 125)	2 x 5 (50 x 125)	11	
			Length	42 (1070)	42 (1070)		
	12	Tilt Angle	Standard mast - fwd/back	6/12	6/12	12	
	13	Overall Dimensions	Length (to face of forks)	105.5 (2680)	105.5 (2680)	13	
			Width (standard tires)	49.2 (1250)	49.2 (1250)	14	
			Mast lowered (OHL)	85.6 (2175)	85.6 (2175)	15	
			Mast extended with LBR	179.4 (4558)	179.4 (4558)	16	
			Height - top of OHG	84.6 (2150)	84.6 (2150)	17	
			Height - top of standard LBR	48 (1220)	48 (1220)	18	
	20	Grade Clearance	Ramp breakover angle	49	49	20	
			Departure angle	43	43		
			Approach angle	41	41		
	21	Turning Radius	Minimum outside	90.6 (2300)	90.6 (2300)	21	
	22	Overhang	Front	18.9 (480)	18.9 (480)	22	
			Rear	19.7 (500)	19.7 (500)	23	
24	Min right angle stacking aisle	Add load length & clearance	109.5 (2780)	109.5 (2780)	24		
PERFORMANCE	25	Speeds Maximum	Travel - forward or reverse	11.8 (19)	11.5 (18.5)	25	
			Lift - full/empty	104.3/114.1 (530/580)	106.3/114.1 (540/580)	26	
			Lowering - full/empty	98.4 (500)	98.4 (500)		
	27	Drawbar Pull Maximum	Full load	4189 (1900)	4321 (1960)	27	
Full empty			4167 (1890)	3858 (1750)			
28	Gradeability Max (1.2 mph)	Full/empty	28 / 24	26 / 25	28		
WEIGHT	29	Truck Weight	Standard truck - no load	9265 (4200)	9520 (4315)	29	
	30	Weight Distribution	Front axle - empty	3825 (1735)	3910 (1775)	30	
			Rear axle - empty	5440 (2465)	5610 (2540)		
			Front axle - with rated load	13700 (6460)	13795 (6500)		
			Rear axle - with rated load	1565 (740)	1725 (815)		
CHASSIS & WHEELS	31	Tire Size	Front	28 x 9-15-12PR	28 x 9-15-12PR	31	
			Rear	6.50-10-10PR	6.50-10-10PR		
	32	Wheelbase		66.9 (1700)	66.9 (1700)	32	
	33	Tread - Center of Tire	Front / rear	40.6/38.6 (1030/980)	40.6/38.6 (1030/980)	33	
			Front dual tires	47.6 (1210)	47.6 (1210)		
		Headroom	SIP to bottom of OHG	42.5 (1080)	42.5 (1080)		
		Counterweight Height		43.3 (1100)	43.3 (1100)		
		Step Height		19.1 (485)	19.1 (485)		
	34	Ground Clearance	Under mast	5.7 (145)	5.7 (145)	34	
			Under power unit	6.5 (165)	6.5 (165)		
Under frame (WB center)			7.3 (185)	7.3 (185)			
35	Service Brake	Type	Drum and Shoe	Drum and Shoe	35		
36	Parking Brake	Type	Hand	Hand	36		
DRIVE LINE	37	Steering	Type	Full Hydraulic	Full Hydraulic	37	
	38	Engine	Model	Nissan K25	Nissan QD32	38	
			Rated Output	SAE gross	hp (kW) @ rpm	62.9 (46.9) @ 2700	55 (41) @ 2000
			Rated Torque	SAE gross	ft-lb (Nm) @ rpm	138.7 (188) @ 1600	143.8 (195) @ 1800
			Displacement		cu in (cm ³)	151.8 (2488)	192.4 (3153)
	39	Transmission	Type	Automatic	Automatic	39	
Number speeds - fwd/rev			1/1	1/1			

Platinum II pneumatic series

Dimensions

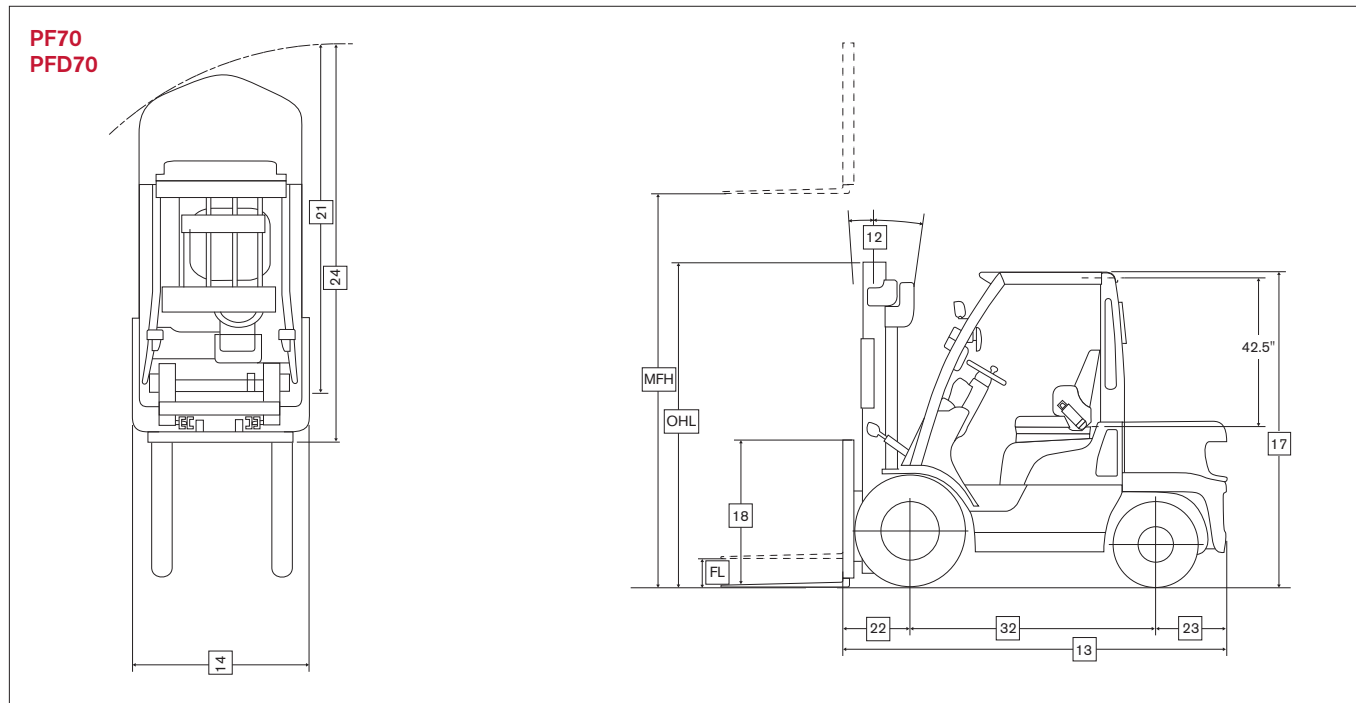

Mast Specifications & Rated Capacities

	Mast Name	Maximum Fork Height	Overall Height Lowered	Free Lift	Tilt Angle Forward/Backward	Rated Capacity at 24" Load Center
TWO STAGE (Wide view 2W)	2W300	118	85.8	6.5	6/12	7000
	2W330	130	91.1	6.5	6/12	7000
	2W350	138	96.1	6.5	6/12	7000
	2W370	146	103.5	6.5	6/12	7000
	2W400	157	113.4	6.5	6/6	6900
	2W450	177	123.2	6.5	6/6	6800
	2W500	197	133.1	6.5	6/6	6600
TWO STAGE (Full free 2F)	2F300	118	85.8	57	6/12	7000
	2F330	130	91.1	62	6/12	7000
	2F350	138	96.1	67	6/12	7000
	2F370	146	103.5	74	6/12	7000
	2F400	157	113.4	84	6/6	6900
THREE STAGE (Full free 3F)	3F355	140	74.2	43.5	6/6	7000
	3F400	157	80.1	49.4	6/6	7000
	3F445	175	86.0	55.4	6/6	6800
	3F485	191	91.3	60.7	6/6	6600
	3F520	205	96.3	65.6	6/6	6300
	3F570	224	103.7	73.1	6/6	5300
	3F620	244	113.6	82.9	6/6	3500
	3F670	264	123.4	92.8	6/6	2500
THREE STAGE Optiview (3V)	3V385	152	80.1	49.4	6/6	7000
	3V430	169	86	55.4	6/6	6900
	3V470	185	91.3	60.7	6/6	6700
	3V505	199	96.3	65.6	6/6	6500
	3V555	219	103.7	73.1	6/6	6200
	3V600	236	113.6	82.9	6/6	4400
	3V650	256	123.4	92.8	6/6	3200
	3V700	276	133.3	102.6	6/6	3000

7,000 lb. capacity

Main Truck Specifications

CHARACTERISTICS	1	Manufacturer's Name		Nissan	Nissan	1		
	2	Model	Model designation	PF70	PFD70	2		
			Long model code	MUG1F2A35JV / LV / DV	MYG1F2A35V			
	3	Rated Load Capacity		lb (kg)	7000 (3500)	7000 (3500)	3	
	4	Load Center	Distance	in (mm)	24 (500)	24 (500)	4	
	5	Power Type			G - LP - G/LP	Diesel	5	
6	Operator Orientation			Sit	Sit	6		
DIMENSIONS	7	Tire Type	Front & rear		Pneumatic	Pneumatic	7	
	8	Wheels	Number (x=driven) front/rear		2 x / 2	2 x / 2	8	
	9	Mast	Maximum fork height	in (mm)	130 (3300)	130 (3300)	9	
			Standard freelif	in (mm)	6.5 (164)	6.5 (164)	10	
	11	Forks	Thickness & width	in (mm)	2 x 5 (50 x 125)	2 x 5 (50 x 125)	11	
			Length	in (mm)	42 (1070)	42 (1070)		
	12	Tilt Angle	Standard mast - fwd/back	degree	6/12	6/12	12	
	13	Overall Dimensions	Length (to face of forks)	in (mm)	108.5 (2755)	108.5 (2755)	13	
			Width (standard tires)	in (mm)	50.4 (1280)	50.4 (1280)	14	
			Mast lowered (OHL)	in (mm)	91.1 (2315)	91.1 (2315)	15	
			Mast extended with LBR	in (mm)	179.4 (4558)	179.4 (4558)	16	
			Height - top of OHG	in (mm)	84.8 (2155)	84.8 (2155)	17	
			Height - top of standard LBR	in (mm)	48 (1220)	48 (1220)	18	
	20	Grade Clearance	Ramp breakover angle	tan (%)	51	51	20	
			Departure angle	tan (%)	39	39		
			Approach angle	tan (%)	51	51		
	21	Turning Radius	Minimum outside	in (mm)	94.1 (2390)	94.1 (2390)	21	
	22	Overhang	Front	in (mm)	19.3 (490)	19.3 (490)	22	
			Rear	in (mm)	22.2 (565)	22.2 (565)	23	
24	Min right angle stacking aisle	Add load length & clearance	in (mm)	113.4 (2880)	113.4 (2880)	24		
PERFORMANCE	25	Speeds Maximum	Travel - forward or reverse	mph (kmh)	11.5 (18.5)	11.5 (18.5)	25	
			Lift - full/empty	fpm (mm/sec)	88.6/92.5 (450/470)	86.6/94.5 (440/480)	26	
			Lowering - full/empty	fpm (mm/sec)	82.7/70.8 (420/360)	82.7/70.8 (420/360)		
	27	Drawbar Pull Maximum	Full load	lb (kg)	4034 (1830)	4056 (1840)	27	
			Full empty	lb (kg)	3968 (1800)	3682 (1670)		
28	Gradeability Max (1.2 mph)	Full/empty	tan (%)	23 / 22	21 / 22	28		
WEIGHT	29	Truck Weight	Standard truck - no load	lb (kg)	10120 (4590)	10375 (4705)	29	
	30	Weight Distribution	Front axle - empty	lb (kg)	3760 (1705)	3850 (1745)	30	
			Rear axle - empty	lb (kg)	6360 (2885)	6525 (2960)		
			Front axle - with rated load	lb (kg)	16215 (7240)	16300 (7280)		
			Rear axle - with rated load	lb (kg)	1905 (850)	2075 (925)		
CHASSIS & WHEELS	31	Tire Size	Front	in	250-15-16PR	250-15-16PR	31	
			Rear	in	6.50-10-12PR	6.50-10-12PR		
	32	Wheelbase		in (mm)	66.9 (1700)	66.9 (1700)	32	
	33	Tread - Center of Tire	Front / rear	in (mm)	41.7/38.6 (1060/980)	41.7/38.6 (1060/980)	33	
			Front dual tires	in (mm)	48.4 (1230)	48.4 (1230)		
		Headroom	SIP to bottom of OHG	in (mm)	42.5	42.5 (1080)		
		Counterweight Height		in (mm)	43.5 (1105)	43.5 (1105)		
		Step Height		in (mm)	19.3 (490)	19.3 (490)		
	34	Ground Clearance	Under mast	in (mm)	5.9 (150)	5.9 (150)	34	
			Under power unit	in (mm)	6.7 (170)	6.7 (170)		
			Under frame (WB center)	in (mm)	7.5 (190)	7.5 (190)		
35	Service Brake	Type		Drum and Shoe	Drum and Shoe	35		
36	Parking Brake	Type		Hand	Hand	36		
DRIVE LINE	37	Steering	Type		Full Hydraulic	Full Hydraulic	37	
	38	Engine	Model		Nissan K25	Nissan QD32	38	
		Rated Output	SAE gross	hp (kW) @ rpm	62.9 (46.9) @ 2700	55 (41) @ 2000		
		Rated Torque	SAE gross	ft-lb (Nm) @ rpm	138.7 (188) @ 1600	143.8 (195) @ 1800		
		Displacement		cu in (cm ³)	151.8 (2488)	192.4 (3153)		
	39	Transmission	Type		Automatic	Automatic	39	
			Number speeds - fwd/rev		1/1	1/1		

Available Equipment

Standard Equipment

- Nissan's own K21 and K25 industrial engines with computer controlled, Electronic Concentrated Control System (ECCS)¹, electronic fuel injection technology, with single-port fuel injection (LP) / multi-port injection (Gas), providing low emission levels, well below EPA Tier II and CARB requirements
- Nissan's own low emission, EPA Diesel Tier III compliant, QD32 industrial diesel engine with an electronic controlled Quick Glow System for dependable starting
- Engine/transmission protection and warning system to safeguard your investment¹
- Operator Presence System includes seat-actuated power interrupt, auto-mast lock, return-to-neutral, audio and visual warnings
- Full suspension seat with operator restraint system
- Seat belt warning system, horn, and back-up alarm
- Tilt-adjustable steering wheel with memory
- Multi-function LCD display with operator PIN security access
- Hour meter, clock, and calendar
- On-board diagnostics and programmable service reminder
- Speedometer and F/N/R transmission indicator
- Engine coolant temperature gauge and low fuel warning light (LP) / fuel gauge (Gas/Diesel)
- Cushioned stability control
- Automatic transmission with drive-by-wire throttle control
- Hydrostatic power steering
- Single lift/tilt hydraulic control lever
- High air intake system combined with cyclone air filter
- Swing-out LP bracket (LP models only)²
- Overhead guard mounted headlights
- 5-piece reinforced overhead guard
- One-piece, no-tool floorboard

Optional Equipment

- Ground speed control (high/low speed settings) and controlled acceleration mode¹
- Dual fuel engine for LP and Gasoline
- UL safety ratings available for LP fuel types²
- Swing-down LP bracket²
- Separate lift & tilt hydraulic control levers
- Fingertip controls²
- Steering wheel with spinner knob
- Swivel seat with rear OHG mounted assist grip with horn button²
- Recycler Special package
- Drive-in racking (30" at 60" / 28" at 54")²
- Extra tilt
- Open core radiator with straight fin & in-line tube design
- Radiator screen
- Diffusion exhaust muffler¹
- Overhead guard mounted pre-cleaner
- Rear combination light package
- Rotating beacons & strobe lights
- Rear work light

¹ Available on Gasoline, LP and dual fuel models only.

² Available on select models. Consult factory.

Technical Information **pneumatic models**

With features designed to exceed expectations in the areas of performance, fuel efficiency, emissions regulations, operator comfort and low cost of ownership, the Platinum II Series is the result of Nissan's relentless pursuit in achieving the perfect balance between the needs of the **Owner, Operator** and the **Environment**.

Electronic Fuel Injection Engine Technology

Platinum II Series' Gasoline, LP, and Dual Fuel models are powered by Nissan's own K21 (2.1 liter) and K25* (2.5 liter) electronic fuel injected industrial engines. Their Electronic Concentrated Control System (ECCS) analyzes engine performance parameters and optimizes engine operation, resulting in enhanced productivity and lower fuel consumption. This system includes three main components: Engine Control Module (ECM), Vehicle Control Module (VCM), and Multi-function LCD Display.

The ECM responds to sensor input by controlling basic engine-related functions, such as proper air/fuel ratio, torque and speed, based on the requirements of the application. The VCM monitors a number of sensors to alert the operator of changing conditions via a full range of warning indicators located on the truck's LCD display. All communication among these components occurs through a Controller Area Network (CAN) system.

Nissan's K-series engines use the same proven block design and bottom-by-pass cooling system as its predecessor, the H-series engine. These enhanced engines are specifically designed and tested for industrial applications in order to deliver all the power and torque (in the low rpm range) to meet the needs of the application. As an added safeguard for your investment, the Platinum II's K21 and K25 engines include an engine/transmission protection and warning system to reduce the speed in the event of excessive heat generation or loss of oil pressure.

Low Emission Engines

Gasoline/LP-Gas/Dual Fuel

Nissan's global commitment to preserving and protecting the environment is evident in the Platinum II Series' ECCS engines, providing exceptionally low emissions levels that are well below EPA Tier II and CARB requirements. Nissan is the first lift truck manufacturer to receive EPA and CARB certification for their own line-up of industrial engines. The K21 and K25's combination of ECCS and three-way catalytic system, which includes an automotive-type closed-loop design, provides enhanced fuel economy and cleaner exhaust emissions.

Diesel

With the Platinum II Series our diesel engines have never been cleaner. Nissan's own QD32 diesel industrial engine offers improved fuel consumption and near elimination of black smoke. Emission levels are well below EPA Tier III requirements. A completely new, electronically regulated, Quick Glow System results in considerably reduced glow times, making it easier to start the engine in cold weather.

Enhanced Work Environment

Several standard features are included in the Platinum II Series to deliver a more comfortable and productive work environment for the operator and those in the surrounding area. Nissan's cushioned stability control design incorporates a maintenance-free rubber dampener located between the rear axle and body to enhance lateral stability under normal driving conditions.

The Nissan K-series engines offer extremely low noise levels at the operator's ear during idle and at maximum travel speeds. An optional ground speed control feature is available to control high or low maximum speed settings, while a controlled acceleration mode adjusts throttle sensitivity to increase fuel efficiency, extend drivetrain life and reduce excessive tire wear.

The Platinum II's Operator Presence System, with seat-actuated power interrupt, incorporates a mast-lock which automatically locks lift and tilt operations when the operator leaves the seat, and a return to neutral feature to minimize forklift movement if the operator leaves the seat while the lift truck is still in gear. This presence system also includes audible and visual warnings if either the seat belt is not engaged while in travel mode, or when the parking brake has not been applied prior to the operator exiting the compartment.

A welded metal assist grip combined with a replaceable metal traction plate that's bolted to the truck's wide, low entry step, provides the operator with sure, comfortable footing and grip for this often repeated task. Nissan's own swing-down LP bracket design uses a gas spring assist to reduce operator effort during tank replacement. This optional feature also incorporates an adjustable bracket to fit various tank sizes.*

Ease of Maintenance

No tools are required to remove the one-piece diamond tread floorboard promoting fast, simple access to hydraulic components and grease fittings. Detachable side panels and a wide-open clamshell hood provide a roomy area for service technicians to perform their tasks. The five-piece reinforced overhead guard simplifies replacement of individual components if necessary, saving time and money. An opening in the dash panel allows for quick and easy brake fluid checks.

A new multi-function LCD display includes on-board diagnostics to keep service time low, with a service reminder in order to stay current with periodic maintenance needs. Its display design provides the operator with excellent visibility and understanding of warning indicators.

Operator Comfort and Control

A spacious operator compartment provides generous foot, leg and head room for a variety of driver sizes. A standard full suspension, fold down seat with soft touch arm pads and hip restraint provides maximum operator comfort and enhanced safety. Its low profile design offers ample head clearance, while front to back travel adjustment allows a comfortable, customized fit for nearly any operator height.

The Platinum II's, tilt-adjustable steering wheel includes a memory lever, to help the operator quickly find his or her ideal driving position, while its compact design offers enhanced control and handling. Hydrostatic power steering minimizes steer effort and operator fatigue. An optional swivel seat produces greater operator comfort and visibility while driving in reverse, and includes a rear assist grip with horn button to further enhance operator productivity and maintain greater control. Automotive-style light and turn signal levers simplify repetitive actions allowing the operator to focus on the job. Optional features designed to enhance load handling efficiency and boost operator productivity include Nissan's exclusive three-stage Optiview mast, providing up to 50% greater visibility. There's also an optional auto tilt leveling system to assist proper mast/fork positioning.

Enhanced comfort results from the Platinum II Series' Operator Comfort System, which includes a full suspension seat, pedals mounted to the chassis frame, and rubber shock absorbers located throughout the vehicle to reduce vibration from the engine and transmission to the operator. For additional vibration reduction, Platinum II Series pneumatic trucks include an automotive-type powertrain mounting design, which incorporates four rubber engine supports.

*Available on select models. Consult factory.

Option Availability

Platinum Series Pneumatic Models

Standard S Option O

		Fuel Types			
		LP	Gasoline	Dual Fuel	Diesel
Vehicle Management	Vehicle Control Module (VCM)	S	S	S	S
	Multi-function LCD display	S	S	S	S
	Security PIN access	S	S	S	S
	On-board diagnostics and service reminder	S	S	S	S
	Engine coolant temperature gauge	S	S	S	S
	Oil pressure, transmission fluid and coolant temperature warning light	S	S	S	S
	Low LP fuel warning light	S	-	S	-
	Fuel gauge	-	S	S	S
Powertrain	Electronic Concentrated Control System (ECCS)	S	S	S	-
	Engine/transmission protection system	S	S	S	-
	Floating power train for reduced vibration	S	S	S	S
	Automatic return-to-neutral	S	S	S	S
	Three-way catalytic converter	S	S	S	-
	Cushioned stability control	S	S	S	S
	Ground speed control – high/low speed selector	O	O	O	-
	Controlled acceleration – power/economy modes	O	O	O	-
	Radiator screen	O	O	O	O
	Diffusion exhaust muffler	O	O	O	-
	UL Safety rating ¹	O	-	-	-
LP System	Swing-out LP bracket ²	S	-	S	-
	Swing-down LP bracket ²	O	-	O	-
Brake	Parking brake with warning buzzer	S	S	S	S
Mast	Seat actuated auto-mast lock system	S	S	S	S
	Optiview three-stage mast	O	O	O	O
Hydraulic System	Single lift/tilt control lever	S	S	S	S
	Separate lift & tilt control levers	O	O	O	O
	Auto-tilt leveling system ³	O	O	O	O
	Hydraulic load sensing valve system	S	S	S	S
Steering System	Tilt steering wheel with memory lock	S	S	S	S
	Hydrostatic power steering system	S	S	S	S
Operator Conveniences	Full suspension seat	S	S	S	S
	OHG-mounted headlights	S	S	S	S
	Back-up warning buzzer	S	S	S	S
	Rearview mirrors	O	O	O	O
	Rear combination light package	O	O	O	O
	Rear work light	O	O	O	O
	Strobe lights & rotating beacons	O	O	O	O

1. Available on select models. Consult factory. 2. Available on most LP and Dual Fuel models. Consult factory. 3. Not available on 7,000-lb. Models using 2-stage masts.



3000-lb, 3500-lb, 4000-lb



4000-lb, 5000-lb, 5500-lb,



6000-lb, 7000-lb



Nissan Forklift Corporation reserves the right to make product changes relating to colors, equipment, specifications or available options without notice. For more information, contact your Nissan Forklift representative.

NISSAN
FORKLIFT